



RHO

Elektronik GmbH

THETA

2-Channel Precision Direction Finder

# RT-202

Compact and  
Easy to use



The RT-202 CrewFinder features compact, robust design and permits fast, efficient recovery in the event of a man overboard incident despite heavy seas and poor visibility. The RT-202 monitors the 121.5 MHz international distress frequency and alarms the crew if an emergency signal is received. The bearing of the source is shown on the LED screen to lead the crew directly to

the person in distress. The “selective squelch” function prevents false alarms caused by interference or other radio signals. The RT-202’s compact antenna also makes it ideal for installation on smaller vessels and lifeboats as well as for landside applications.

## SAR (Search and Rescue) and “Man overboard” applications

A “man overboard” emergency is always terrifying – for the person in distress as well as for crew members. Under poor conditions, it can be almost impossible to find someone in the water and whether or not the individual is found is a matter of luck. To make matters worse, search and rescue services are usually not available due to the lack of a seamless infrastructure or SAR personnel cannot reach the person in the water before it is too late. The RT-202 makes it possible to reach and rescue overboard crew members quickly and easily despite adverse weather and water conditions.

All crew members are equipped with personal locator beacons (PLB), which can be either attached to their life jackets or worn on their person.

The transmitter is activated either manually or through immersion in water. This triggers transmission of a signal on the international emergency frequency (121.5 MHz). The azimuth of the source of the signal is then automatically displayed on board the vessel to within  $\pm 10^\circ$ , and a loud acoustic signal is triggered at the same time. This enables the skipper to turn the vessel in the direction of the source of the signal to approach the individual in the water. Since the direction finder operates over 360° azimuth, the signal cannot be lost while maneuvering.

The RT-202 CrewFinder is a robust, easy-to-operate MOB rescue device that is ideal for use on virtually all vessels or offshore installations.



## Electrical data

Method of bearing:	Doppler principle (3 kHz frequency of rotation)
Bearing accuracy <sup>1</sup> :	±5°
Internal resolution:	1°
Sensitivity:	< 2 µV/m
Reception frequencies:	121.500 MHz + 121.650 MHz (customer-specific frequencies available on request)
Bearable modulation:	A3E, F3E, A3X (distress modulation), bearing largely independent of modulation
Polarization:	Vertical
Polarization error:	≤ 5° at 60° field vector rotation
Garbling cone:	Approx. 30° to the vertical
Response time <sup>2</sup> :	≤ 50 ms (with sufficient reception field strength)
Operating voltage:	12 V to 28 V DC
Power consumption:	Max. 350 mA (without external speaker)
Monitoring:	With built-in miniature speaker, modulation: A3E

## Interfaces

Serial RS-232 (V24):	1200 baud, parity = odd, 7 data bits, 1 stop bit
Audio out:	For external loudspeaker (on GND) approx. 5 V <sub>pp</sub> on 8 Ω, output power approx. 0.5 W
Alarm out:	Open collector output to GND with reception signal / alarm: U <sub>out</sub> < 1.0 V DC (I <sub>max</sub> : approx. 100 mA)

## Mechanical data

Operating temperature:	-20 °C to +60 °C		
Weight:	Display Control Unit (DCU):	approx. 600 g	
	Antenna Unit (AU):	approx. 1400 g	
Dimensions:	DCU:	length x width x height	120 mm x 100 mm x 55 mm
	AU:	diameter x height	260 mm x 600 mm
Ingress protection:	IP 67 (The use of the mast sealing kit is recommended to protect the antenna connector against moisture.)		
Lateral thrust due to wind:	Approx. 14 N at 150 km/h wind speed Approx. 20 N at 180 km/h wind speed		

<sup>1</sup> With undisturbed wave field and sufficient field strength. Measured by changing the angle of incidence with the antenna rotating on a revolving table in order to eliminate environmental influences on the results.

<sup>2</sup> Very weak signals can increase response time considerably!



## Features

- Completely automatic operation
- Very high receiver sensitivity to permit detection of very weak or remote signals
- Bearing information displayed on a circular LED direction indicator
- Selective alarm function to prevent false alarms
- Signal strength indicator
- Compact and robust construction ensures exceptional reliability
- All DF components are waterproof (IP 67)
- Easy to install: no RF cables required
- Interface for remote operation and data transfer to a PC



POM housing (standard)



Aluminum housing with panel mounting brackets

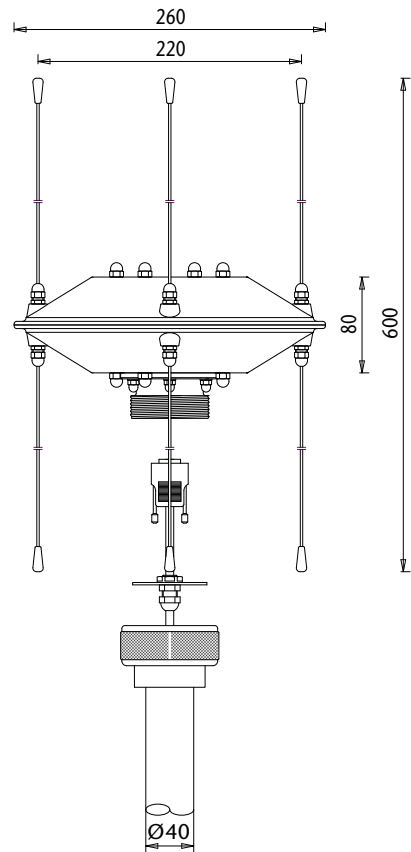

Screw flange (standard)



6-hole-flange

All product specifications subject to change without notice.

## Contact Information



**RHO** *The Leader in DF*  
International Inc **THETA**

**RHOTHETA International Inc**

**8201 Peters Rd Ste 1000**

**Ft Lauderdale FL USA**

**+1 954 495 8700**

**info@rhothetaint.com**

**service@rhothetaint.com**