

User Manual **Installation and Operation**

SAR-DF 517

Wideband Precision Direction Finder

with extended COSPAS-SARSAT range & special scan modes

- *Standard Version*
- *Law Enforcement Version*



BECKER
AVIONICS, INC.

R H O

The Leader in DF

Elektronik GmbH

THETA



Edited by:

Becker Avionics, Inc.
10376 USA Today Way
Miramar, FL 33025
USA

Tel.: 954-450-3137
Fax: 954-450-3206

Internet: www.beckerusa.com
E-Mail: info@beckerusa.com

Copyright © RHOTHETA Elektronik GmbH
All rights reserved
Issue: [2008/12/17] [Rev 2.00.a]

- Edition valid for DCU [Systemstatus 4.01 ...] & [Software Rev 3.02 ...]
- Edition valid for AU: [Systemstatus 5.03 ...] & [Software Rev 3.01 ...]

Note:

The manufacturer reserves the right on making modifications of the product described herein at any time and without previous information.

Index

1 GENERAL INFORMATION	5
1.1 Purpose of use of the direction finder	5
1.2 Scope of delivery	6
1.3 Important basic adjustments	6
2 OPERATING	7
2.1 General Operating Principles	7
2.1.1 Power-On procedure	8
2.1.2 Main Pages Selection	9
2.1.3 Dimming function	9
2.1.4 Squelch Operation	10
2.2 Direction Finder Mode	12
2.2.1 Operating Elements in Bearing Mode	12
2.2.2 Standard Display in Bearing Mode	13
2.2.3 Special Options in COSPAS-SARSAT Bearing mode	14
2.2.4 COSPAS-SARSAT Decode Window	15
2.2.5 121.500 MHz bearing Window in COSPAS-SARSAT mode	16
2.2.6 COSPAS-SARSAT Scan Mode	16
2.3 Law Enforcement and Medical Operation	17
2.3.1 LoJack Pages	17
2.3.2 ETS Pages	19
2.3.3 Med Track Pages	19
2.3.4 Law Enforcement Scan Mode	19
2.4 Frequency Selection Page	20
2.4.1 Frequency Selection Page, Standard Version	20
2.4.2 Frequency Selection Page, Law Enforcement Version	21
2.5 Memory Page	21
2.6 Setup Page	22
3 ERROR MESSAGES	24
4 INSTALLATION	25
4.1 Antenna unit	25
4.2 Display unit	26
4.3 Cable Connection / Wiring	26
4.4 Installation Examples	27
5 TECHNICAL DATA	28
5.1 Electric features	28
5.2 Interface	29
5.3 Mechanical features	30
6 APPENDIX	32
6.1 Frequencies of channels on maritime band	32
6.2 Serial interface data protocol (short description)	33

List of figures

Control Unit Overview	7
Power-On Screen.....	8
Page Selection	9
Dimming Setup.....	9
Five Examples for Squelch operation	11
Operational Elements in Bearing Mode	12
Display in Bearing Mode	13
Operational Elements and Display in COSPAS-SARSAT Bearing Mode	14
COSPAS-SARSAT Decode Window	15
121.500 MHz Bearing Window in COSPAS-SARSAT Mode.....	16
Display in COSPAS-SARSAT Scan Mode.....	16
LoJack Bearing Screen	17
ID-Only Mode Menu Options.....	17
ID Editing Sub-Page.....	18
ID Only Mode Menu with defined ID	18
AutoSquelch during Med Track Operation.....	19
Frequency Selection Page and Operating Elements	20
Memory Page	21
Accessing Setup Page	22
Setup Page.....	23
Error Message.....	24
Mounting drawing of the antenna.....	25
Mounting hole pattern for the display.....	26
Connecting cable / wiring	26
Drawing of Display	30
Drawing bearing antenna	31
Timing: Serial Data Protocol	35

1 General information

RHOTHETA Elektronik GmbH is the developer and manufacturer of the Direction Finder System SAR-DF 517.

1.1 Purpose of use of the direction finder

This modern precision direction finder was mainly developed for professional SAR (search and rescue) and LE (Law Enforcement) purposes.

There are existing two versions:

- The standard version, which offers the possibility to bear and analyze either traditional emergency frequencies in the UHF and VHF band, the general distress calling channel 16 of maritime radio and the common COSPAS/SARSAT emergency signal
- The Law Enforcement version, which offers the possibility to bear the traditional VHF emergency frequency, the common COSPAS/SARSAT emergency signal and different LE-signals (LoJack, ETS and Med-track)

The complete COSPAS/SARSAT Frequency range (also future channels) is supported by this direction finder. For practical use, there is also a very fast scanning mode for detecting any possible COSPAS/SARSAT frequency within one pulse period (< 400 ms) available.

The excellent bearing results becomes possible due to our newly developed patented antenna concept (small, robust and wide-banded) and the sophisticated bearing analyzing algorithms, which deliver a quick but nevertheless steady display.

The direction finder was developed to be used under rough conditions such as mobile use on aircrafts or vehicles.

1.2 Scope of delivery

- Display Control Unit
- Antenna Unit (with Receiver and DF-controller)
- Connector set for cable (antenna ↔ display) and power-supply.



1.3 Important basic adjustments

In order to achieve best use of the direction finder, the user is able to perform several adjustments of configuration. These adjustments can be set up in the setup menu (refer to chapter Operating / Setup Page).

The most important adjustments are:

- Mounting position (adjustment of downside or upside mounting)
- External (remote) dimming of display
Important: If using the external dimming, the limits of the external analog voltage (min / max.) have to be adjusted correctly in the direction finder setup menu.

For a description of these adjustments, please refer to chapter Operating / Setup Page.

2 Operation

Operating the direction finder is deliberately very simple with its clearly arranged layout. Except the upper page rotary switch and the ON/OFF pushbutton, the function of the operating elements always depends on the active page. All relevant adjustments can be controlled on the display. Figure 1 shows the general layout of the control unit's surface.

2.1 General Operating Principles



Control Unit Overview

- (1) **>LC Graphic Display<** (128 x 64 dots dot-matrix display, dark blue on yellow-green background) showing all relevant operational information depending upon the selected page.
- (2) **>Menu<** options for rotary and push buttons: If a field with dark background and bright text is shown below a button or switch, the function described in this field may be selected through the operational element above or below this menu field. In case of the Page Menu, the active page is high-lighted with dark background, while the inactive page is in black letters.
- (3) **>ON/OFF<** Push-button to switch on / off the system.
- (4) **>Volume<** Rotary Switch, used, depending on the active page, to adjust the volume of the audio output or to select frequency values (MHz steps).
- (5) **>SQL<** Rotary Switch, used, depending on the active page, to adjust the squelch function or to select specific functions on a page depending upon the interactive menu on the display.
- (6) **>CLR / F1<** Push-button. If pushed for a short time, this button activates the function F1 described in the interactive menu on the display below. If pushed for a longer time (ca. 3 seconds), this button activates the CLEAR function.
- (7) **>STORE / F2<** Push-Button. If pushed for a short time, this button activates the function F2 described in the interactive menu on the display below.

- (8) **>Rep / DIM<** Push-Button. If pushed for a short time, this button activates the setup of the display dimming function. If pushed for a longer time (ca. 3 seconds), this button activates the repetition of the last valid bearing and signal level information.
- (9) **>Page<** Rotary Switch to select displayed main pages (“DF” or “MEM”). Together with the DIM button, it is used to set the display brightness (dimming function).
- (10) **>Frequency<** Rotary Switch to select frequencies.

2.1.1 Power-On procedure

After switching on the unit through the ON/OFF Push-Button, a start screen is shown on the LC-Display for five seconds:



Power-On Screen

- (1) **The upper line** is showing the name of the product.
- (2) **The second line** is showing the sub-version of the equipment, that means either “**LE Version**” for the Law Enforcement version, or “**Standard Version**” for the standard version.
- (3) **The fourth line** is showing the web address of the manufacturer, RHOETHA Elektronik GmbH.
- (4) **The lowest line** displays software version and serial number information for the antenna unit and (5) for the display control unit.

After five seconds, the equipment switches into the operational mode by displaying the last active main page before having been switched off, that means either the DF (Direction Finder) or the MEM (Memory) page.

2.1.2 Main Pages Selection

There are two main pages which can be selected:

The **DF** (Direction Finder) Page is the page in which all relevant operational information is shown, depending on the kind of signal which shall be received.

The **MEM** (Memory) Page is the page in which memorized operational frequencies can be modified.



- (1) The **>Page<** rotary switch is used to select the active page.
- (2) The **active page** is highlighted with dark background
- (3) The **inactive page**, which may be selected, is written in dark letters on bright background.

Page Selection

2.1.3 Dimming function

The background of the LC-graphic display is equipped with a LED-array, whose brightness may be adjusted continuously (from 5 to 100%). Dimming will be performed in an exponential curve, thus allowing very accurate adjusting under night-conditions



- (1) Pressing the **>Rep/DIM<** button for a short time is activating the dimming setup mode.
- (2) **Brightness** information, as percentage value from 5 % to 100 % in steps of 5 % is displayed instead of the "Page" field in the upper right corner of the display.
- (3) The **>Page<** rotary switch can be used to adjust the display brightness. Right-hand turn will increase the value in steps of 5 percent, while a left-hand turn will reduce the value in steps of 5 percent.

Dimming Setup

After ca. 3 seconds of user inactivity, the display falls back into the prior main page. The adjusted brightness of the display will remain stored after switching off the unit.

Dimming of legends may be performed in two ways, using the internal dimming settings as for the LC-display itself, or using an external (remote) dimming voltage provided by the aircraft.

Internal dimming (on display unit) of legends:

Internal dimming is always active, if the external dimming input is not connected, or if applied voltage is below 1 V DC. (Refer to the wiring plan). The legends are dimmed in the same manner as the LC display.

External (remote) dimming of legends:

As soon as there's a voltage >1 V DC at the dimming input, the brightness of legends is controlled externally by an analog signal. (Refer to the wiring plan and to the operating/setup-menu description).

2.1.4 Squelch Operation

The main challenge in direction finder operations is to only use the signal transmitted by the destination for calculation of the bearing. Noise and other disturbances shall not cause misleading bearing indications.

In order to prevent the direction finder to calculate bearing results which are misled due to noise and disturbances, several means are given:

If a signal can be distinguished from noise and other signals by its message content (e.g. LoJack ID), only transmissions containing the required message content are used for bearing.

In other cases, the squelch can be used to suppress unwanted weak signals and noise. A squelch level, called threshold, has to be set by the user or automatically by the system. All signals which have a level below this threshold value will be ignored. Signals above this level will cause a bearing indication.

As a result, a signal to be used for bearing has to be so much stronger than the noise or disturbing signals that the receiver can clearly distinguish between wanted and unwanted signals.

The result of this requirement is that the sensitivity is reduced to the level set by the squelch threshold. This results in a reduced maximum distance to the transmitter.

However, it might be desirable to achieve bearing information even for weakest-possible signals which are very close to the noise level. In this case, it is possible to reduce the squelch level below the noise level. As soon as the modulation of a signal can be heard in the loudspeaker, it can be expected that bearing is possible.

If the noise itself is a randomly distributed noise (so-called white noise), and there is no other signal receiver, the bearing indication itself will be randomly distributed. If the noise is not white noise but a disturbance, bearing will show to the source of the noise.

If there is a very weak signal "in the noise", this signal will produce a correct bearing indication thanks to sophisticated bearing technologies used in the SAR-DF 517 system. Fluctuations due to noise will be small even at low signal levels, however the reaction time of the bearing indication can increase.

To verify if a bearing indication is due to white noise or due to an internal disturbance source, respectively, or if it is due to a real receive signal, the aircraft should make a slow turn. If the bearing indication is due to an external signal, e.g. a SAR beacon, the bearing indication has to compensate the changed relative flight angle.

Example: Bearing indication is 30°. The signal is weakly audible in the loudspeaker due to being deep in the noise. The airplane makes a turn left by 60°. If the bearing indication is not changing to approximately $30^\circ + 60^\circ = 90^\circ$ after a few seconds, the bearing is likely to be due to noise or internal disturbances off the aircraft.

Note: The weaker a signal is, the longer it will take to change the bearing. Durations around 5 seconds are not unfamiliar in such cases. Therefore, it is not useful to use this procedure for signals with short transmission times and low transmit duty cycles, such as COSPAS-SARSAT transmission. The procedure is best suited for ELT transmission with a continuous signal and still well-suited for ELTs with intermittent transmission (down to 33%).

In cases where pulsed signals are to be received, the receiver is able to decide himself which squelch level is best-suited for normal operation. In such cases, an automatic squelch is provided. The threshold is automatically set to a value higher than the calculated noise level. The difference in dB between noise and threshold level can be defined in the Setup Menu. Refer to the chapter "Setup Page" for details. During automatic squelch operation, the user has the possibility to force the squelch into manual mode, but has to care about the operational limitations described in this chapter.

In cases where the Antenna Unit checks signal validity autonomously and without useful possibilities of user interaction, user interaction is not possible and the squelch purely follows internal rules appropriate to the kind of received signal.

Examples of different squelch settings:

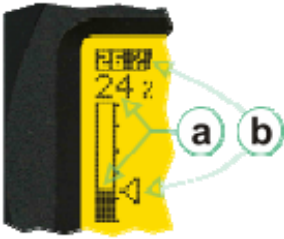

Without received signal, the noise level **(a)** is below the correctly chosen squelch level **(b)**. The receiver audio output remains quiet, and no bearing is indicated.

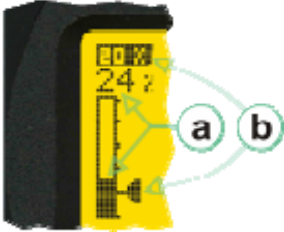

With the same received noise level **(a)**, but wrongly set squelch level **(b)**, there will be an erroneous, noisy bearing available if there is no receive signal available at that time.



If the squelch is operating in automatic squelch mode, this is indicated by a sign "A" **(c)** above the squelch level marker. Depending on the SN-Ratio Setup, the squelch level is set slightly higher than the noise level. Using the SQL rotary switch (1), the user would be able to force the squelch level to a manual setting. Automatic setting can be re-entered by setting the manual setting to < 0 % or > 60 %.



Strong, short receive signals will not modify the squelch level setting.



If the squelch functionality is controlled by the system, without user interactions being allowed, this is indicated by a "X" sign **(c)** above the squelch level marker.

Five Examples for Squelch operation

2.2 Direction Finder Mode

Generally, the direction finder mode is used to track bearing information towards a transmitter. It shows all basic information depending of the kind of signal to be tracked.

Mainly, differences in how information is displayed are related to the information content of tracked signals. Basic information and basic operational possibilities are applicable for signals with no additional information content, such as 121.500 MHz sweep-tone modulated SAR beacon signals.

In case of signals with additional information content, such as COSPAS-SARSAT data messages, additional sub-pages may be activated.

2.2.1 Operating Elements in Bearing Mode



Operational Elements in Bearing Mode

The picture above shows the state of the display while the equipment is operated on the international emergency frequency 121.500 MHz with an active signal being received.

- (1) **>FREQUENCY<** Rotary switch selecting the active frequency. The last selected frequency remains stored after switching off/on the device. The selected frequency is shown on the graphic display bottom right. Above, additional information for the selected frequency is displayed. The use of the rotary switch activates a sub-page. Please refer to the Frequency Selection section for details.
- (2) **>VOLUME<** Rotary switch to adjust the audio output level. The volume of a linked external speaker or amplifier can be adjusted in a range from 0 (off) to 99 (maximum loudness). The selected volume is shown in the bottom left corner of the graphic display. The volume remains stored after switching off/on the device.
- (3) **>Squelch Level<** adjusts the squelch level. The squelch level has to be above the receiving level without signal (noise). Only signals above the squelch level are audible in the loudspeaker and used by the direction finder for bearing indication. The **>SQL<** rotary switch allows to select the squelch threshold, i.e. a minimum signal strength of an incoming signal to be processed. The current settings on a signal level scale from 0 % to 60 % is shown in bright letters on dark background below the SQL rotary switch and as an arrow beside the signal Strength Bar-Graph.
- (4) The **>CLR<** Push-button is used for erasing the internal bearing value averaging store and the Last Signal Timer. To activate this function, the push-button has to be hold down for a minimum of circa three seconds. The sophisticated averaging store increases bearing precision and enables at all an usable bearing display in case of

bad receiving signals (if there is a far away transmitter and/or temporary complete loss of a receiving signal). Caused by the averaging procedure, a drag error may occur, which might be disturbing the bearing indication after a quick change of course of the aircraft or vehicle. In this case, the indicated bearing value lags by the real bearing value for about two seconds (for very weak signals even longer). By pressing this push-button after a quick change of course, the display will show the new bearing value without drag error. Additionally, the CLR Push-Button is used to activate specific functions high-lighted in the menu below the button:

- (5) >STORE< push-button: Without function except if a special function is high-lighted in the menu line of the display.
- (6) >REPEAT< Push-button, when pressed, showing the last valid bearing value with corresponding receiving level.
- (7) >PAGE< Rotary switch to leave the DF mode in order to switch to the MEMORY (MEM) Page / Mode.

2.2.2 Standard Display in Bearing Mode

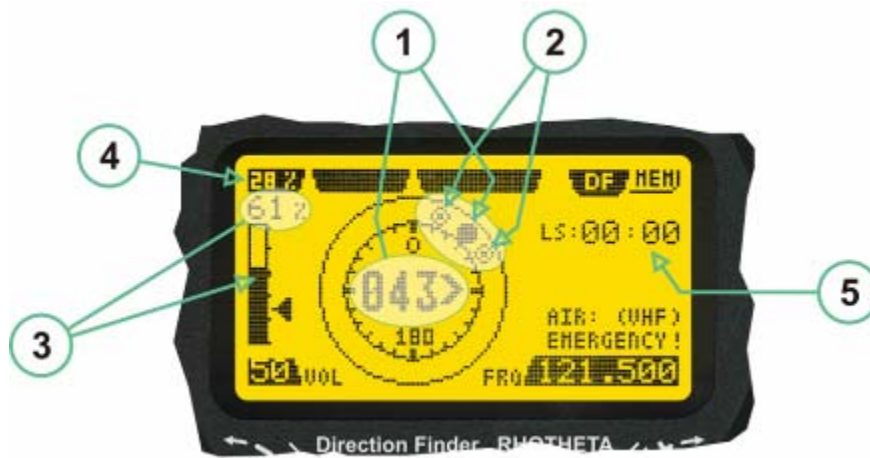

Display in Bearing Mode

- (1) >Relative Bearing value<, by means of a sophisticated averaging procedure, a steady display is accomplished, either as graphic display or as text in the range of 0°... 359°. (0° corresponds to bearing direct ahead).
- (2) >Spread<, maximum deviation of un-averaged bearing values. This is an indicator of bearing quality. The wider the range between the directions of maximum deviation, the worse the received signal is. As a result of the excellent averaging procedure, even with a spread of 45°, good bearing results are achieved.
- (3) >Receiving level< (field strength) of the signal as a relative percentage value, visualized as bar-graph indication and as decimal value. Even without a received signal a certain noise level may be displayed.
- (4) >Squelch level< (independently adjustable and stored for each frequency). Squelch level is indicated as marker at the Signal Strength Bar-Graph or as direct relative level value. A usable bearing analysis can only be achieved if the squelch level is above the noise level (without received signal). If the antenna unit is placed close a heavily disturbing electronic devices, the squelch level has to be raised, thus making the direction finder being less sensitive. In receive modes where the squelch level is set automatically, an "A" above the marker indicates the "Autosquelch" functionality.
- (5) >Last Signal< timer showing the time since a signal has been received for the last time (i.e. since a signal has been stronger than the squelch level). Values are "minutes:seconds".

2.2.3 Special Options in COSPAS-SARSAT Bearing mode

Especially for the use together with beacons transmitting a data signal according to COSPAS-SARSAT specifications in the 406-MHz-Band, special functionalities and pages are being provided.

After selection of a COSPAS/SARSAT Frequency (Refer to the chapter "Frequency selection Page"), the bearing page provides additional information and operating options.



Operational Elements and Display in COSPAS-SARSAT Bearing Mode

- (1) **>Auto Squelch<** indication, indicating that the squelch level is set automatically to be close to the noise floor. It is recommended to always use the Auto Squelch during COSPAS-SARSAT operation. This can be achieved by manually selecting 0 % (lowest possible value) or 60 % (highest possible value) as squelch level. During COSPAS-SARSAT-Operation, this will force the automatic setting of the level.
- (2) **>Decode<** menu option, allows to open the COSPAS/SARSAT Decode sub-page by shortly pushing the F1 push-button above the menu option.
- (3) **>>121.500<** menu option. The COSPAS-SARSAT signal in the 406 MHz band is transmitted only every 50 seconds in form of a short data burst of 440 or 520 ms. Approaching the transmitter, it will be received earlier than the 121.500 MHz continuous signal due to its high transmitter power. However, in a lower distance to a transmitter, bearing on 121.500 MHz is faster thanks to the continuous or rapidly intermittent signal. The 121.500 MHz menu option allows a direct switch-over to 121.500 MHz. Direct return back from 121.500 to the COSPAS-SARSAT band is possible from the 121.500 MHz bearing Window in COSPAS-SARSAT mode. Please refer to the chapter "121.500 MHz bearing Window in COSPAS-SARSAT mode" for details.
- (4) **>Frequency range<** indication. COSPAS-SARSAT is using a channel spacing of 3 kHz for its beacons. Due to the internal architecture of the direction finder, it is possible to receive more than one channel in the same time. Thus, frequency steps of the direction finder are 8.33 kHz instead of 3 kHz. The receive frequency covered by the current receive frequency setting is shown in the display line above the receive frequency indication.

Important:

If the exact frequency of the COSPAS-SARSAT beacon is unknown, it is strongly recommended to use the COSPAS-SARSAT scanning functionality for detecting the correct frequency (Refer to the chapter "Frequency selection Page" & "COSPAS-SARSAT Scan Mode")

2.2.4 COSPAS-SARSAT Decode Window

The COSPAS-SARSAT Decode Window allows decoding incoming COSPAS-SARSAT data messages.



COSPAS-SARSAT Decode Window

- (1) **>Exit<** push button (F1 button) allows to leave the decode window and to go back to the COSPAS-SARSAT bearing mode window.
- (2) **>Decode<** in the upper right corner of the display indicates that the decode function is activated.
- (3) **>Country<** displays the COSPAS-SARSAT Country Code coded into the received data message.
- (4) **>Last Signal<** time since the last COSPAS-SARSAT message has been received in minutes:seconds format.
- (5) **>Position<** field showing, in case of location protocols being used by the beacon, the encoded GNSS position data (latitude / longitude) transmitted by the beacon.
- (6) **>Range<** field showing the range of COSPAS-SARSAT channels covered by the actual receive frequency setting.
- (7) **>15-HEX-ID<** 15-HEX-ID of the beacon in hexadecimal format.
- (8) **>Data string<** of the bits 25 to 112 of the COSPAS-SARSAT data burst in case of short messages, and bits 25 to 144 in case of a long message format. The last 8 Hex Values are separated by a blank. Bit- and Frame-synchronization hex values (Bits 1 to 24) are suppressed to increase the readability of the data message.
- (9) **>X<** sign to indicate that the Squelch is controlled by the antenna unit for optimum sensitivity. The user has no access to the Squelch setting.

2.2.5 121.500 MHz bearing Window in COSPAS-SARSAT mode

While being in the 121.500 MHz bearing window activated through the COSPAS-SARSAT Bearing Mode sub-page, the bearing window is slightly different to the normal bearing window:



Differences are:

- (1) **>406.xxx<** push button (F2 button) allows to switch back to the last used 406 MHz frequency. This allows to quickly check on 121.500 MHz if a beacon can already be received on VHF and, in the case that this is not possible, to cycle back to 406 MHz quickly.
- (2) **>CP-SAR-SAT<** indication shows that the actual page belongs to the COSPAS-SARSAT page section.

121.500 MHz Bearing Window in COSPAS-SARSAT Mode

2.2.6 COSPAS-SARSAT Scan Mode

If the COSPAS-SARSAT scan mode has been selected, the COSPAS-SARSAT channels, as selectable manually from the Frequency Selection Page, are scanned. After reception of a valid COSPAS-SARSAT Signal, the COSPAS-SARSAT bearing mode is activated. Due to the fast scanning – the complete COSPAS-SARSAT sub-band is scanned within less than 400 ms – detection of a receivable COSPAS-SARSAT signal is possible within one COSPAS-SARSAT repetition cycle.



Display in COSPAS-SARSAT Scan Mode

- (1) **>SCAN<** flashing indication notifying the user that the equipment is operating in scan mode.
- (2) **Frequency** display indicating the COSPAS-SARSAT scanning frequency range.
- (3) **>X<** sign showing that squelch settings are controlled autonomously by the receiver.

Scan mode can be left by entering a new frequency through the frequency or memory setup.

2.3 Law Enforcement and Medical Operation

The functions described in this chapter only apply to the law enforcement version of the direction finder equipment.

Law enforcement direction finders are able to track transmitter for

- LoJack stolen car recovery
- ETS stolen money carrying cases recovery
- Med Track for persons in helpless situations recovery

2.3.1 LoJack Pages

After selecting the LoJack frequency through the Frequency Selection Display, the LoJack bearing window is displayed.



LoJack Bearing Screen

- (1) **>Automatic Squelch<** indication. It is strongly recommended to operate the receiver with automatic squelch sensitivity setting in case of LoJack operation. However, manual setup of the Squelch level would be possible. Please refer to the chapter "Squelch Operation" for details.
- (2) **>ID Filter<** hotkey (F2 push-button): Allows activation of ID-only mode. This filter mode allows receiving one single LoJack transmitter identified by its ID. The shown text (FILT=OFF) indicates that no filter has been activated yet.

After activation of the ID-only mode, the user is asked by the system to enter an ID:



ID-Only Mode Menu Options

- (1) **>EDIT<** hotkey (F1 push-button). This button opens the LoJack ID editing sub-page.
- (2) **>ID only<** indication. The field indicated that the receiver is operating in the filter mode. By pressing the F2 button, ID-only mode can be left.

The ID may be entered through the editing sub-page in several ways:



ID Editing Sub-Page

- (1) **>VALUE<** Data field showing the last received LoJack ID of any active VLU within receive range. In case that no LoJack ID has been received, the value field is filled with dashes (“-----”).
- (2) **>Value to ID<** hotkey (F2 push-button) allows to copy the received LoJack ID in the ID field.
- (3) **>ID<** field showing the LoJack ID which shall be selected. If no LoJack ID has been selected, the ID field is filled with dashes (“-----”). Manual entry of data is possible. The position of the ID field which can be modified manually is high-lighted by dark background and bright values.
- (4) **>Select<** rotary switch, allowing to select which position of the ID field shall be modified manually.
- (5) **>Value<** rotary switch, allowing to modify the currently selected position within the ID field.
- (6) **>Exit<** hotkey (F1 push-button), allowing to switch back to the LoJack bearing window.

If an ID has been selected successfully, the LoJack bearing window indicates the selected Lojack ID and the ID-only mode. In this case, the squelch is controlled by the antenna unit without possibility of user influence, indicated by an “X” ahead the squelch level marker. The direction finder will calculate bearing information only while he receives a transmission with the selected ID, thus the squelch is not necessary and only would reduce system sensitivity.



ID Only Mode Menu with defined ID

- (1) **>ID<** menu option showing the currently selected ID and allowing, by pressing the F1 push-button, to re-enter the ID editing sub-page.
- (2) **>ID only<** menu option showing that currently the ID only mode is active. By pressing the F2 push-button, the ID-only mode may be deactivated.

2.3.2 ETS Pages

The Law Enforcement version of the SAR-DF 517 system is supporting the tracking of ETS transmitters. If an ETS frequency has been selected, the bearing window for ETS opens. Its operational use is similar to the standard bearing window.

2.3.3 Med Track Pages

“Med Track”, patient tracking, allows to track persons wearing a small transmitter helping to recover them e.g. in cases of disorientation or unconsciousness.

If a medical tracking frequency has been selected, the standard bearing page is slightly modified:



- (1) The squelch level is set automatically, indicated by a letter **>A<** above the squelch level marker. It is recommended to leave the squelch in automatic mode.
- (2) To reactivate the automatic squelch mode after unintentional manual modification of the squelch level, manually increase the squelch level through the **>SQL<** rotary switch to the maximum value (60 %).

AutoSquelch during Med Track Operation

There are no special functional options available.

Reception of a signal above squelch level is indicated by an acoustic signal (beep tone).

Med Track frequencies always have to be selected through the MEMORY page, i.e. the receive frequency has to be a memory channel, selected through the frequency selection page.

2.3.4 Law Enforcement Scan Mode

If the Law Enforcement Scan Mode has been selected, the receiver scans ETS and LoJack frequencies for signals.

On the LoJack frequency, the receiver is staying receiving for a longer period of time. The scanning criterion is the reception of a LoJack VLU signal with valid LoJack ID.

On the ETS frequencies, normal manual squelch settings for ETS frequencies are used, and the scan mode stops as soon as a signal is being received.

Reception of signals, which stop the scan mode, will result in the appropriate bearing page to be activated.

Frequency	Application	Criterion
Country-Specific LoJack-Frequency	LoJack	Valid LoJack ID
216.4875 MHz	ETS	Squelch Level
216.5125 MHz	ETS	Squelch Level
219.930 MHz	ETS	Squelch Level
219.960 MHz	ETS	Squelch Level

2.4 Frequency Selection Page

If the frequency selection page has been activated by using the frequency selection rotary switch, the frequency selection page opens. The frequencies which can be selected consist of several frequency blocks: Memory Channels, Special Application Frequencies, COSPAS-SARSAT frequencies, and scan modes.



Frequency Selection Page and Operating Elements

- (1) **>Frequency<** information field, showing all necessary information on the selected frequency such as frequency in MHz, memory channel (in case of memory frequencies), purpose of the selected frequency.
- (2) **>Marker<** showing the currently chosen frequency on the frequency scale
- (3) **>Frequency scale<** on which a frequency can be chosen. The frequency scale is organized in frequency blocks. The name of the frequency block is indicated below the frequency scale. They are:
 - Law Enforcement scanning frequencies (Law Enforcement version only)
 - Memory Channels
 - Fix pre-programmed frequencies
 - COSPAS-SARSAT frequencies
 - COSPAS-SARSAT scanning frequencies.
- (4) **>Frequency selection<** rotary switch allowing to select a frequency by moving the marker along the frequency scale.
- (5) **>Exit<** hotkey (F2 push-button) allowing to directly switch back to the normal operating mode on the currently selected frequency. If the exit hotkey is not pressed, the direction finder will fall back into the operating mode automatically after ca. 5 seconds of user inactivity.

2.4.1 Frequency Selection Page, Standard Version

In the standard version of the equipment, the frequency selection page offers a set of 16 different choices, organized in 4 blocks, which can be selected by the user.

Frequency selection options for the standard version of the RT-600:

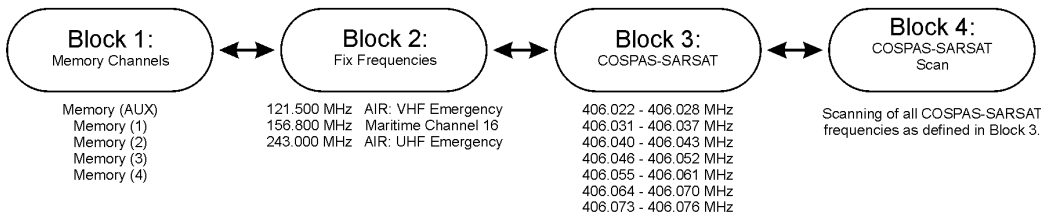

2.4.2 Frequency Selection Page, Law Enforcement Version

In the law enforcement version of the equipment, the frequency selection page offers a set of 20 different choices, organized in 5 blocks, which can be selected by the user.

Frequency selection options for the law enforcement version of the RT-600:

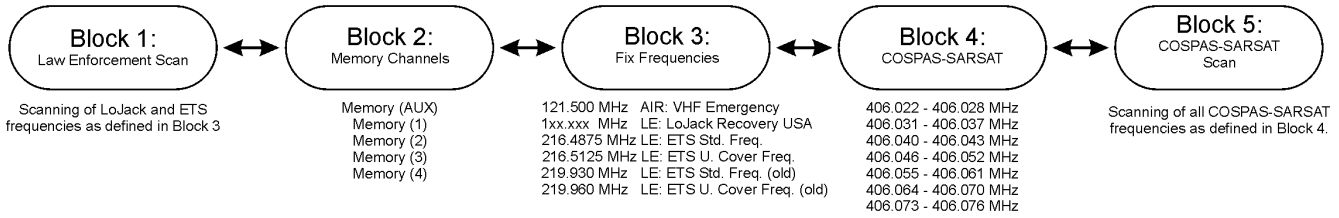

2.5 Memory Page

If the memory page is selected, the user is able to program the five available memory channels. After selecting and/or modifying a memory channel, switching back to the direction finder page will take over the currently selected memory channel to the direction finder mode.



Memory Page

- (1) **>Channel Name<** field: indicates the name of the channel, which is re-used in other displays as name of the currently used frequency: AUX, (1) ... (4).
- (2) **>Frequency<** field: shows the frequency currently stored for each channel. The memory channel currently selected for modification or for transfer to the direction finder mode is highlighted by dark background and bright ciphers on the frequency field.
- (3) **>Application Information<** field showing to which frequency band and application a frequency belongs to.
- (4) **>Channel selection<** rotary switch used to select which memory channel shall be active for modification or transfer into direction finder mode.
- (5) **>MHz<** rotary switch used to modify the selected memory in steps of 1 MHz
- (6) **>kHz<** rotary switch used to modify the selected memory in steps appropriate to the concerned frequency band.

Depending on the frequency band, different frequency step sizes are pre-programmed:

Frequency Range	Step Size	Application Band	Applicable for:
118.000 – 123.000 MHz	8.33 kHz	Air VHF	Standard Version Law Enforcement Version
156.000 – 162.025 MHz	25 kHz	Maritime VHF	Standard Version Only
164.000 – 174.000 MHz	12.5 kHz	LE: LoJack	Law Enforcement Version Only
201.000 – 215.995 MHz	5 kHz	Med Track	Law Enforcement Version Only
216.000 – 218.9875 MHz	12.5 kHz	LE: ETS	Law Enforcement Version Only
219.000 – 220.000 MHz	10 kHz	LE: ETS	Law Enforcement Version Only
240.000 – 246.000 MHz	8.33 kHz	Air UHF	Standard Version Only
400.000 – 410.000 MHz	8.33 kHz	CP-SAR-SAT	Standard Version Law Enforcement Version

2.6 Setup Page

System setup functions are available in the setup page. The functions described in this section should be used by trained personal only.



Accessing Setup Page

The setup page can be accessed by holding down the >CLR< (1) and >REP< (2) buttons simultaneously and, in the same time, performing a left-hand turn on the >Page< rotary switch (3).

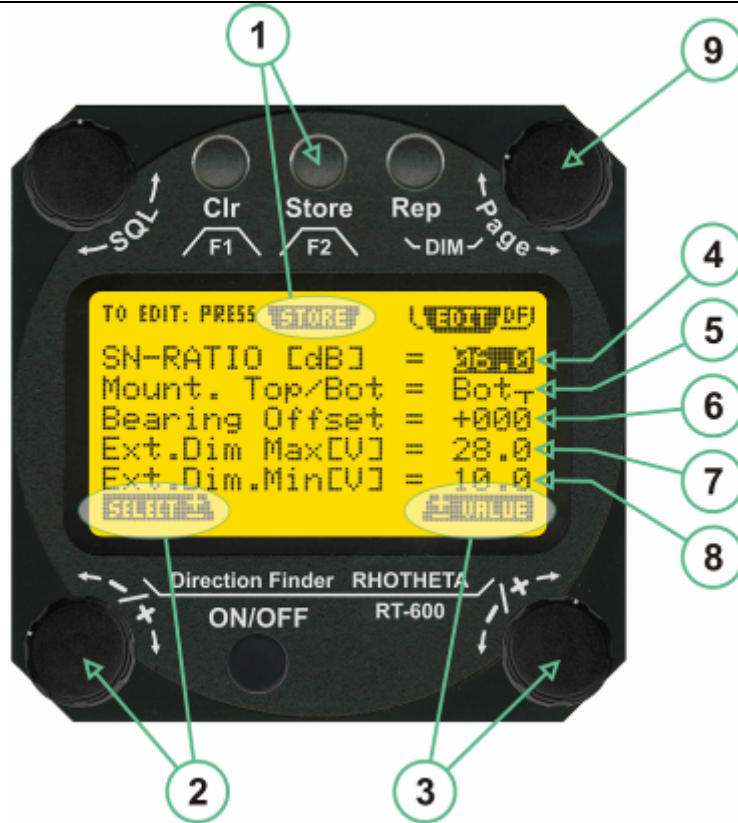

Setup Page

- (1) **>Store<** push-button must be pressed in parallel if a value of a setting shall be modified. If a value can be modified, the background stops to blink.
- (2) **>Select<** rotary switch used to scroll through the menu options. The value of the actually activated menu option is high-lighted with dark background and blinking.
- (3) **>Value<** rotary switch used to change values in menu options (**>Store<** (1) has to be pressed in parallel if a value shall be modified).
- (4) **>SN-Ratio<** menu option representing the necessary Signal-To-Noise-Ratio (Difference between signal and noise level) used as criterion for the automatic squelch function. Please refer to the chapter "Squelch Operation" for details. Default value is 6.0 dB.
- (5) **>Mounting Position<** menu option to select Top- or Bottom-Mounting of the DF antenna. In case of rooftop installation (e.g. on land vehicles), "**Top**" shall be selected. In case of bottom-down (upside-down) installation (e.g. on a helicopter), "**Bot**" shall be selected. If this option is not selected correctly, all bearing values will be mirror-inverted.
- (6) **>Bearing Offset<** menu option to include a constant offset correction to the bearing indication. Bearing values in degrees will be changed according to the offset value.
- (7) **>Maximum External Dimming Voltage<** menu option which sets the upper limit of the dimming input voltage.
- (8) **>Minimum External Dimming Voltage<** menu option which sets the lower limit of the dimming input voltage.
- (9) **>Page<** rotary switch to be turned right-hand to go back to the Direction Finder page. A left-hand turn on this rotary switch will show up an additional service page with debug information used for system checks.

3 Error messages

If an internal error of the device is recognized, a corresponding, flashing error message will be shown in the DF pages:

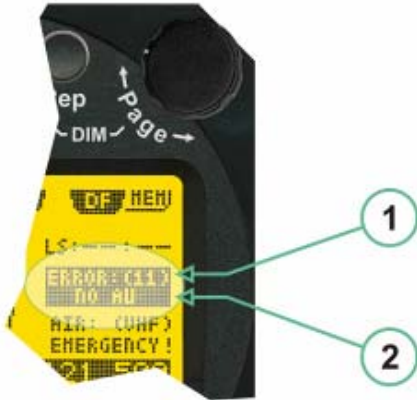

Error Message

- (1) **Error message** including **error code** (in brackets)
- (2) **Short description** of the indicated error.

In case of coincidence of various errors, the error with the highest priority will be displayed.

Error message	Error, location	Reason
Error: (12) VOLT.DU	Main voltage supply	Main Voltage input too low (≤ 10.0 V)
Error: (11) NO AU	Connection: antenna → display or Antenna Unit	No serial data (RS485) from Antenna Unit. No or damaged connection between antenna and display, or damaged antenna unit.
Error: (10) BAD AU	Connection: antenna → display	Incompatibility or bad data connection between display and antenna.
Error: (9) BAD RU	Remote Unit:	Incompatibility or bad data connection between display and external serial Remote Unit or PC
Error: (8) VOLT.AU	Antenna Unit:	Voltage supply at Antenna Unit too low (≤ 9.0 V). Main voltage supply too low or considerable drop of voltage between display and antenna.
Error: (7) BAD DCU	Connection: Display → Antenna	Incompatibility or bad data connection between antenna and display.
Error: (6) NO DCU	Connection: Display → Antenna	No serial data from Display Unit to Antenna Unit.
Error: (5) PLL ERR	antenna	Error in synthesizer-oscillator of receiver in Antenna Unit.
Error: (4) FRQ+OFS	received transmitter	Received frequency too high (more than 6 KHz / error of transmitter)
Error: (3) FRQ-OFS	received transmitter	received frequency too low (more than 6 KHZ / error of transmitter)
Error: (2) DECODE	radio distance: transmitter ↔ DF	Data Bits of decoded signal (COSPAS-SARSAT or LoJack) defective
Error: (1) DATARNG	Incompatibility of: data DCU ↔ AU	Protocol data bytes out of valid range.
Error: (0) NO REC	Antenna Unit: receiver	Receiver board defective

4 Installation

4.1 Antenna unit

A convenient position of the monopole bearing antenna is crucial for good bearing results. The antenna needs an effective ground connection to the body of the aircraft or to the roof of the vehicle. If there is no metallic mounting surface available, a metallic sheet or similar (net) with connection to ground has to be applied first between vehicle-body and antenna.

In this hatched area, the antenna touches the body of the vehicle/aircraft. In order to obtain a good ground connection, the surface of the body should be bared. (Measuring unit [mm])

8 x holes for mounting the antenna unit to the vehicle / aircraft.

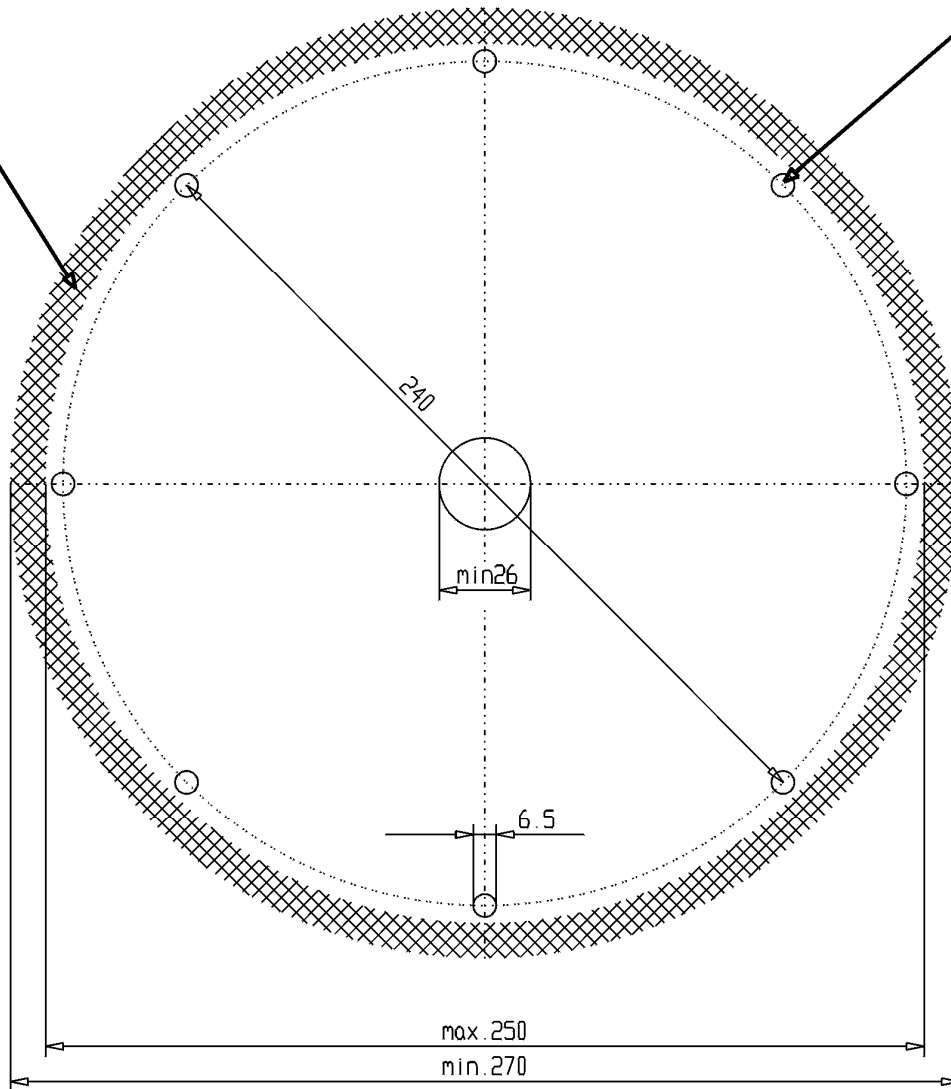

Mounting drawing of the antenna

4.2 Display unit

The display unit may be mounted into a front panel by the means of this mounting drawing:

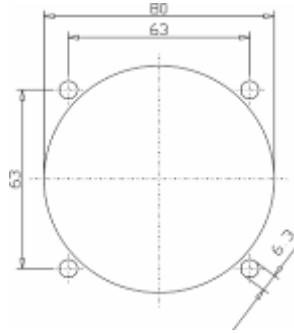

Mounting hole pattern for the display

4.3 Cable Connection / Wiring

(Also refer to chapter Technical data for details)

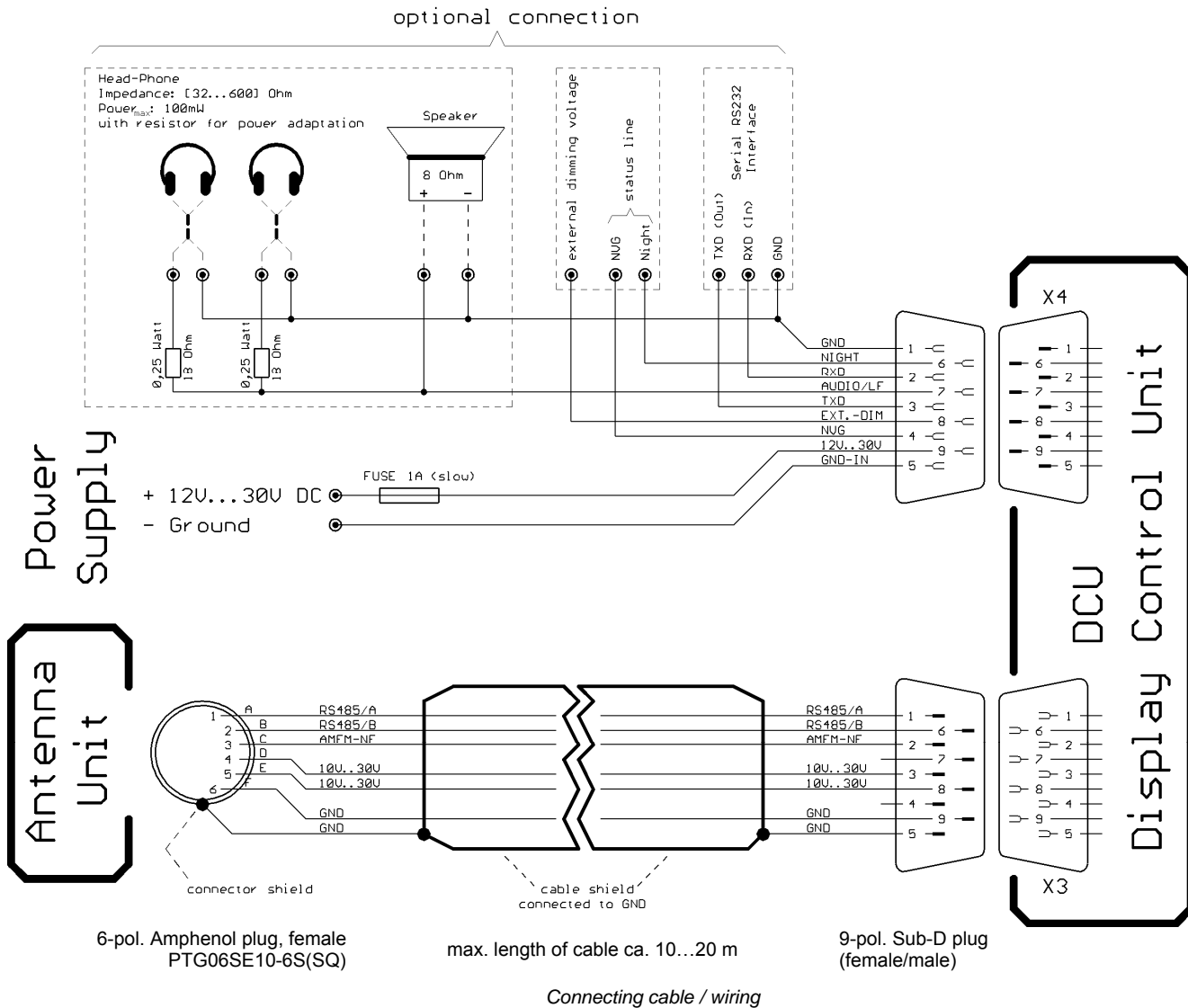

4.4 Installation Examples

Typical installations on helicopters:

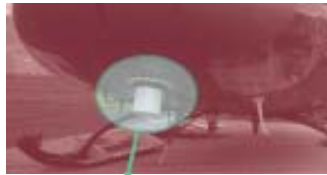

Typical installations on airplanes:



5 Technical data

5.1 Electric features

Method of bearing:	Doppler-principle (3 kHz rotational frequency, right / left rotation)	
Bearing accuracy ¹ :	± 5°	
Internal resolution:	1°	
Sensitivity:	RF-Voltage at Receiver Input (50 Ω): VHF < 100 nV; Maritime Band < 100 nV; UHF < 100 nV; 406 MHz < 150 nV LoJack < 100 nV, ETS < 200 nV, Med Track < 200 nV	
Frequency stability:	±2.0 ppm ($\Delta f/f = \pm 2 \cdot 10^{-6}$) [at Temperature range -30 °C...+80 °C]	
Receiving channels:	15/18 (five of them are free adjustable)	
Receiving frequencies: (or see type plate for special customer options)	Standard Version 118.000 ... 123.000 MHz 156.000 ... 162.025 MHz 240.000 ... 246.000 MHz 400.000 ... 410.000 MHz	Law Enforcement Version 118.000 ... 123.000 MHz 164.000 ... 174.000 MHz 201.000 ... 220.000 MHz 400.000 ... 410.000 MHz
Special Scanning modes:	LE version: automatic scanning for LoJack and ETS signals Standard version: complete maritime ship band scanning within 3 sec	
COSPAS-SARSAT Frequencies	Channel A...S / 406.022 ... 406.076 MHz	
COSPAS-SARSAT fast scan mode	Full automatic detection of any active COSPAS-SARSAT channel A... within 400 msec	
COSPAS-SARSAT analysis:	Reception and analysis / decoding of COSPAS-SARSAT data signals (112 Bit (short message) resp. 144 Bit (long message), 400 baud, biphasic L encoded, phase modulation, with Bose-Chaudhuri-Hocquenghem error-correcting code / specified in accordance to COSPAS-SARSAT C/S T.001 October 1999)	
Bearable kinds of modulation:	A3E, F3E, A2X (ELT-modulation), F1D, G2D, COSPAS-SARSAT bearing largely independent of modulation.	
Polarization:	Vertical	
Error of polarization :	≤ 5° at 60° field vector rotation	
Garbling cone:	Ca. 30° to the vertical	
Time of response: ² :	≤ 20 ms (with sufficient receiving field strength)	
LC-graphic display	128 x 64 dots, supertwist / transflective, extended range of temperature, dark-blue display on yellow-green background, background light. Freely adjustable (exponential) dimming of brightness	
Supply voltage range:	12 V to 35 V DC	
Current consumption:	LCD-background light Off: max. 350 mA (12 V DC) / 200 mA (24 V DC) LCD-background light 100 %: max. 600 mA (12 V DC) / 300 mA (24 V DC)	

¹Undisturbed wave field and sufficient field strength proposed. Measuring by changing the angle of incidence, the bearing antenna rotates on a revolving table in order to eliminate influences of environment to the bearing result.

²Very weak signals can considerably increase the time of response!

5.2 Interface

External connections (optional / at Sub-D 9-pol. Connector X4 male)

Dimming:

Pin 8	external voltage input for variable dimming of legends. (optional)	Analog input signal for variable control of the legends illumination. Input voltage is freely adjustable in the range of 1.5 ... 33 V in the setup menu. Refer to chapter "Setup Page". Default setting 10 ...28 V. (10 V = Off, 28 V = max. dimming) Input Impedance: > 50 k Ω
Pin 6	night status line (optional)	Low-active. At input voltage < 2,5 V the dimming operates in night mode. Maximum brightness ca. 4% of day/default mode brightness. Input Impedance: > 50 k Ω
Pin 4	NVG status line. (optional)	Low-active. At input voltage < 2,5 V the dimming operates in NVG mode. Maximum brightness ca. 2% of day/default mode brightness. Input Impedance: > 50 k Ω

Audio/LF:

Pin 7	Audio output signal	AC coupled voltage source with very low inner resistance. Maximum output voltage ca 8 V _{PP} = 2,83V _{RMS} at maximum Volume. Maximum output power ca. 2 W with 4 Ω speaker. If a headphone is connected ([32...600] Ω / 100mW), we recommend using a resistor (18 Ω / 0.25 W) between audio output and headphone to prevent damage of the headphone.
-------	---------------------	---

Serial interface RS232: (9600 baud, 8 data bits, 1 stop bit, no parity)

Pin 3	TXD	Serial output (ca. \pm 10 V)
Pin 2	RXD	Serial input (ca. \pm 10 V)

5.3 Mechanical features

Temperature range:

Display

- permissible operating temperature³: -20 °C ... +60 °C
- permissible storage temperature: -30 °C ... +80 °C

Antenna

- permissible operating temperature³: -40 °C ... +60 °C
- permissible storage temperature: -55 °C ... +80 °C

Protective system:

- bearing antenna: IP 67

Weights:

- display unit: 250 g
- bearing antenna: 2000 g

Dimensions:

- display unit: 82 mm x 82 mm x 43 mm (width x height x depth)
- bearing antenna: Ø270 mm x 185 mm

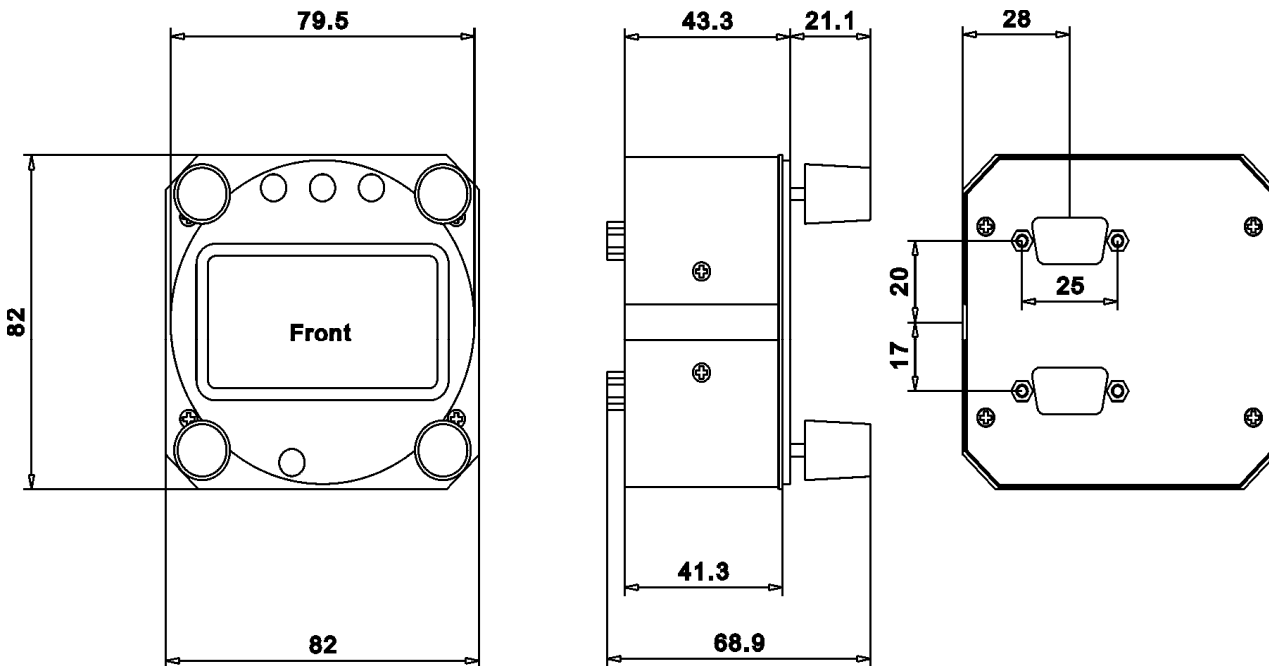

Drawing of Display

³ For temperatures lower than -10° C a warm-up period of 15 min should be allowed

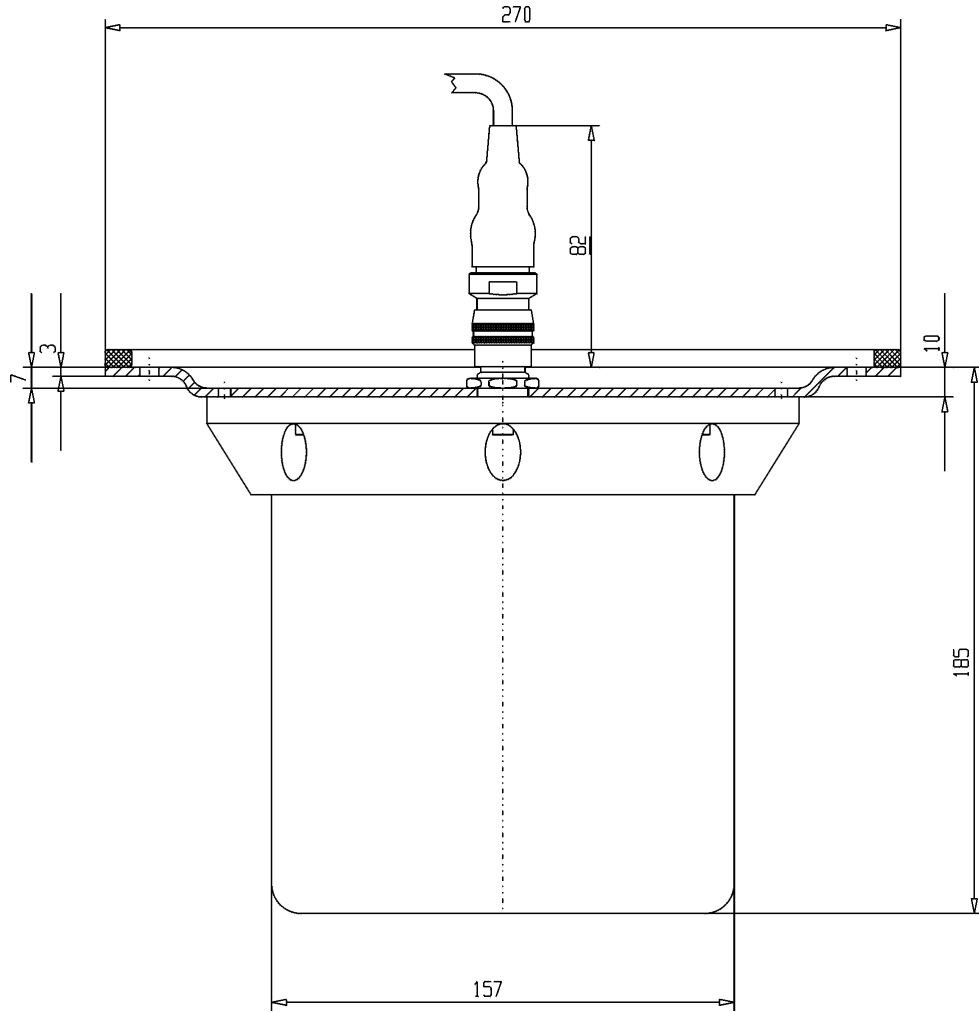

Drawing bearing antenna

6 Appendix

6.1 Frequencies of channels on maritime band

(only for standard version)

Frequency-range of the SAR-DF 517 in the maritime band: 156.000 MHz ... 162.025 MHz

Channel No.	frequency (ship - station)	Frequency (coast - station)
1	156,050 MHz	160,650 MHz
2	156,100 MHz	160,700 MHz
3	156,150 MHz	160,750 MHz
4	156,200 MHz	160,800 MHz
5	156,250 MHz	160,850 MHz
6	156,300 MHz	160,900 MHz
7	156,350 MHz	160,950 MHz
8		156,400 MHz
9		156,450 MHz
10		156,500 MHz
11		156,550 MHz
12		156,600 MHz
13		156,650 MHz
14		156,700 MHz
15		156,750 MHz
16		156,800 MHz
17		156,850 MHz
18	156,900 MHz	161,500 MHz
19	156,950 MHz	161,550 MHz
20	157,000 MHz	161,600 MHz
21	157,050 MHz	161,650 MHz
22	157,100 MHz	161,700 MHz
23	157,150 MHz	161,750 MHz
24	157,200 MHz	161,800 MHz
25	157,250 MHz	161,850 MHz
26	157,300 MHz	161,900 MHz
27	157,350 MHz	161,950 MHz
28	157,400 MHz	162,000 MHz
60	156,025 MHz	160,625 MHz
61	156,075 MHz	160,675 MHz
62	156,125 MHz	160,725 MHz
63	156,175 MHz	160,775 MHz
64	156,225 MHz	160,825 MHz
65	156,275 MHz	160,875 MHz
66	156,325 MHz	160,925 MHz
67		156,375 MHz
68		156,425 MHz
69		156,475 MHz
70		156,525 MHz
71		156,575 MHz
72		156,625 MHz
73		156,675 MHz
74		156,725 MHz
75		156,775 MHz
76		156,825 MHz
77		156,875 MHz
78	156,925 MHz	161,525 MHz
79	156,975 MHz	161,575 MHz
80	157,025 MHz	161,625 MHz
81	157,075 MHz	161,675 MHz
82	157,125 MHz	161,725 MHz
83	157,175 MHz	161,775 MHz
84	157,225 MHz	161,825 MHz
85	157,275 MHz	161,875 MHz
86	157,325 MHz	161,925 MHz
87	157,375 MHz	161,975 MHz
88	157,425 MHz	162,025 MHz

6.2 Serial interface data protocol (short description)

Interface RS232: 9600 Baud, 8 databits, 1 stoppbit, no parity

Specification serial output:

There is send out cyclic (250ms..300ms) a binary datastream (39 bytes), which contains all relevant DF-bearing informations.

The datastream starts with a header (value = 0xA0 as Id for bearing mode).

The next bytes contain different values for status, bearing information and also service.

The last byte is used for datastream checksum control.

Register of databytes (for details see next page):

byte no.	
[0]	Header = 0xA0 Id for Bearing Mode
[1]	Number = of bytes in the complete message (including header and checksumbyte)
[2]	Status HSB [x x x x x x x x] LSB <div style="margin-left: 20px;"> ----- -----> Receiving ----- -----> Squelch controlled by AU (X) ----- -----> Permission RL Calibration ----- -----> Line Night ----- -----> Line NVG ----- -----> Dimming External </div>
[3]	(Not used)
[4..5]	Error (Bits[12..0])
[6]	Actual DCU Page
[7]	Volume [0..100]%
[8..11]	Frequency [Hz]
[12]	Active Band
[13]	Actual Squelchlevel [0..60]%
[14]	Audio-Line & _NF_Test Output
[15]	(Not used)
[16..17]	Voltage_DC ([0..335]=[0 ... 33.5]V)
[18..19]	Voltage_AU ([0..255]=[0 ... 25.5]V)
[20]	Temperature_AU [-68..+127]°C
[21]	Frequency Offset [-99..+99]
[22..26]	(Not used / reserved)
[27]	Level [0..100]%
[28..29]	Bearing Averaged [0..359]° relative
[30..31]	Bearing Live_Min [0..359]° relative
[32..33]	Bearing Live_Max [0..359]° relative
[34]	Test Value PS-RAM Right Rotation[0..178] (for service only)
[35]	Test Value PS-RAM Left Rotation [0..178] (for service only)
[36..37]	(Not used / reserved)
[38]	Checksum is the 2's complement of the modulo-256 sum of all bytes without checksum-byte [0..n-1]

Detailed Description of important values for practical use:

- **Status:** byte [2]
Receiving Bit 0 of this value (LSB) indicates signal receiving.
If Bit 0 = Low, then no signal is received and so on no bearing is available.
If Bit 0 = High, then bearing is possible.
- **Error:** bytes[4..5] → 16 bit value
each set bit corresponds to the error no. (Refer to the chapter Error messages)
Example: - 0x0000 → No error
 - 0x0800 → Bit No. 11 Set (= No AU Error)
- **Frequency:** bytes [8..11] → 32 bit value
actual adjusted frequency [Hz]
Example: - 0x073DF160 → 121500000 → 121.5 MHz
- **Actual Squelchlevel:** byte [13] Range: [0..60]%
without signal, the actual squelchlevel should always be adjusted a little bit over the noise level
(Refer to the chapter Squelch operation)
- **Level:** byte [27] Range: [0..99]%
actual receiving level (without signal this value is equal to the noise level).
If a signal is received, then this value corresponds to the signal strength of this signal.
- **Relative Bearing averaged:** byte [28..29] → 16 bit value Range [0...359, 0xFFFF]
if the value = 0xFFFF, then no valid bearing is available, otherwise this value contains the actual averaged bearing information in Deg. [0°..359°].
Example: - 0X0114 → 276° bearing (= left side oriented to heading)
- **Bearing Live Min/Max:** byte[30..31] & [32..33] → 16 bit values Range [0...359, 0xFFFF]
Only for signal quality or additional information – NOT recommended for bearing indication
The relative live bearing field contains the max/min bearing in degrees without averaging. The relative live bearing reacts faster than the normal relative bearing, but it has not the precision of the averaged bearing.
The Min/Max Bearing Values are calculated within a time period of approx. 250ms. If they are very close together (for example “124” and “128” degrees), then the signal quality is quite good. A wide span of the min/max values (for example “97” and “162”) shows very noisy, but nevertheless bearable signal quality.

Specification serial input: (optional)

The serial input is normally only used for service and maintenance. Nevertheless it is possible via this interface, to remote control the actual frequency and the squelchlevel of the DF system.

If a valid datastream is send to the DF, then the actual frequency selection at the DCU is switched to Block2 / AUX0. At this memory channel the new frequency is stored and used automatically. (Refer to the chapter Frequency Selection Page). If the frequency is changed (by one valid datastream) no more serial input is necessary. The actual frequency can be changed at any time by manual operation at the DCU.

The timing of serial input (if used) is strictly fixed. The optional serial input has to take place directly after a serial output (max. 50 ms delay time).

If a new changed frequency is commanded to the DCU via this serial input interface, it can take up to 1 sec of time until this new frequency is ready for operation/bearing. It is strictly not recommended to use the frequency remote control for any scan mode. The frequency control has to be used for static frequency change only.

Register of databytes:

byte no.															
[0]	Header 0xC0														
[1]	Number of bytes in the complete message (including header and checksumbyte)														
[2..4]	(not used for normal operation / any byte values allowed)														
[5..8]	<table border="1"> <tr> <th colspan="2">Frequency [Hz]</th> </tr> <tr> <th>Valid Range for Standard Version:</th> <th>Valid Range for LE Version:</th> </tr> <tr> <td>118000000 ... 123000000 [Hz] @ 8.333 kHz</td> <td>118000000 ... 123000000 [Hz] @ 8.333 kHz</td> </tr> <tr> <td rowspan="2">156050000 ... 162025000 [Hz] @ 5.000 kHz</td> <td>164000000 ... 174000000 [Hz] @ 8.333 kHz</td> </tr> <tr> <td>201000000 ... 215995000 [Hz] @ 5.000 kHz</td> </tr> <tr> <td rowspan="2">240000000 ... 246000000 [Hz] @ 8.333 kHz</td> <td>216000000 ... 218995000 [Hz] @ 12.500 kHz</td> </tr> <tr> <td>219000000 ... 220000000 [Hz] @ 10.000 kHz</td> </tr> <tr> <td>400000000 ... 410000000 [Hz] @ 8.333 kHz</td> <td>400000000 ... 410000000 [Hz] @ 8.333 kHz</td> </tr> </table>	Frequency [Hz]		Valid Range for Standard Version:	Valid Range for LE Version:	118000000 ... 123000000 [Hz] @ 8.333 kHz	118000000 ... 123000000 [Hz] @ 8.333 kHz	156050000 ... 162025000 [Hz] @ 5.000 kHz	164000000 ... 174000000 [Hz] @ 8.333 kHz	201000000 ... 215995000 [Hz] @ 5.000 kHz	240000000 ... 246000000 [Hz] @ 8.333 kHz	216000000 ... 218995000 [Hz] @ 12.500 kHz	219000000 ... 220000000 [Hz] @ 10.000 kHz	400000000 ... 410000000 [Hz] @ 8.333 kHz	400000000 ... 410000000 [Hz] @ 8.333 kHz
Frequency [Hz]															
Valid Range for Standard Version:	Valid Range for LE Version:														
118000000 ... 123000000 [Hz] @ 8.333 kHz	118000000 ... 123000000 [Hz] @ 8.333 kHz														
156050000 ... 162025000 [Hz] @ 5.000 kHz	164000000 ... 174000000 [Hz] @ 8.333 kHz														
	201000000 ... 215995000 [Hz] @ 5.000 kHz														
240000000 ... 246000000 [Hz] @ 8.333 kHz	216000000 ... 218995000 [Hz] @ 12.500 kHz														
	219000000 ... 220000000 [Hz] @ 10.000 kHz														
400000000 ... 410000000 [Hz] @ 8.333 kHz	400000000 ... 410000000 [Hz] @ 8.333 kHz														
[9]	Squelchlevel [0..60]%														
[10..11]	(not used for normal operation / any byte values allowed)														
[12]	Checksum is the 2's complement of the modulo-256 sum of all bytes without checksum-byte [0..n-1]														

Timing:

The serial output takes place cyclic each 250 ms (without request). All available internal values are sent out as a binary coded data stream.

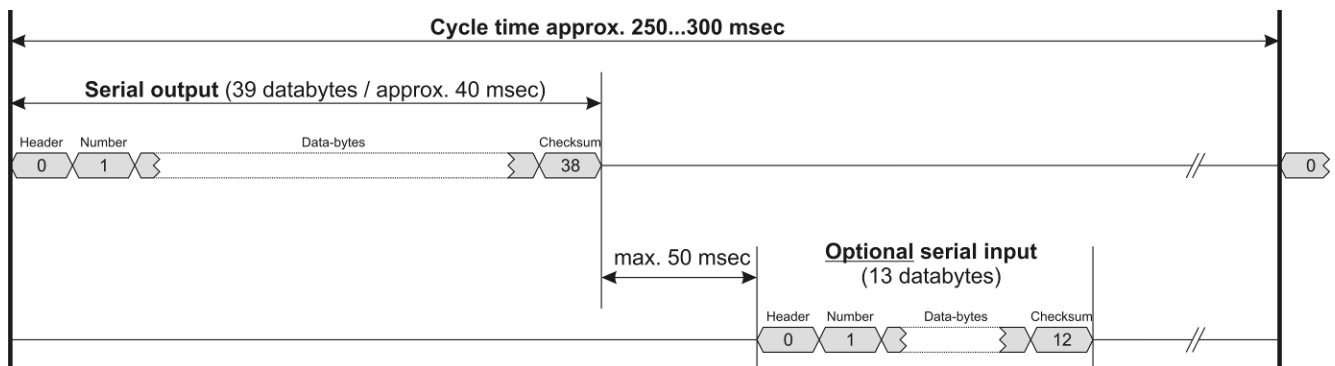

Timing: Serial Data Protocol