

User Manual

Line Protection for Mast Integration

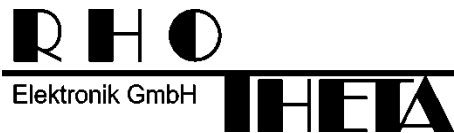

Edited by:

RHOTHETA Elektronik GmbH
Kemmelpark
Dr.-Ingeborg-Haeckel-Str. 2
82418 Murnau
Germany

Tel.: +49 8841 4879 - 0
Fax: +49 8841 4879 - 15

Internet: www.rhotheta.de
E-Mail: email@rhotheta.de

*Copyright © RHOTHETA Elektronik GmbH
All rights reserved
- Issue: 2016/10/24 [Rev 1.00.a]
- Document-ID: 12-9-2-0024-3-1-60*

Note

The manufacturer reserves the right to make modifications at any time and without previous information of the here described product.

Content

1 Short Description..... 4

2 Connection Diagram..... 4

 2.1 Component Description5

 2.2 Description of External Cables5

3 Front View 6

4 Mechanical Characteristics..... 8

5 Wiring Diagram 8

6 Notes..... 9

1 Short Description

The line protection for mast integration includes all necessary components for overvoltage protection of antenna control lines and the RF-Signal line (see Connection diagram).

The line for mast integration is necessary if the DF antenna is installed on RHOTHETA Antenna Mast and the distance between the DF antenna and DF main unit is less than 15 meters.

The line protection system is housed in an IP66 water-tight cabinet suitable for outdoor installation on the antenna mast. Electrical interconnection is made by cables which enter the cabinet through sealed connectors located on the bottom.

2 Connection Diagram

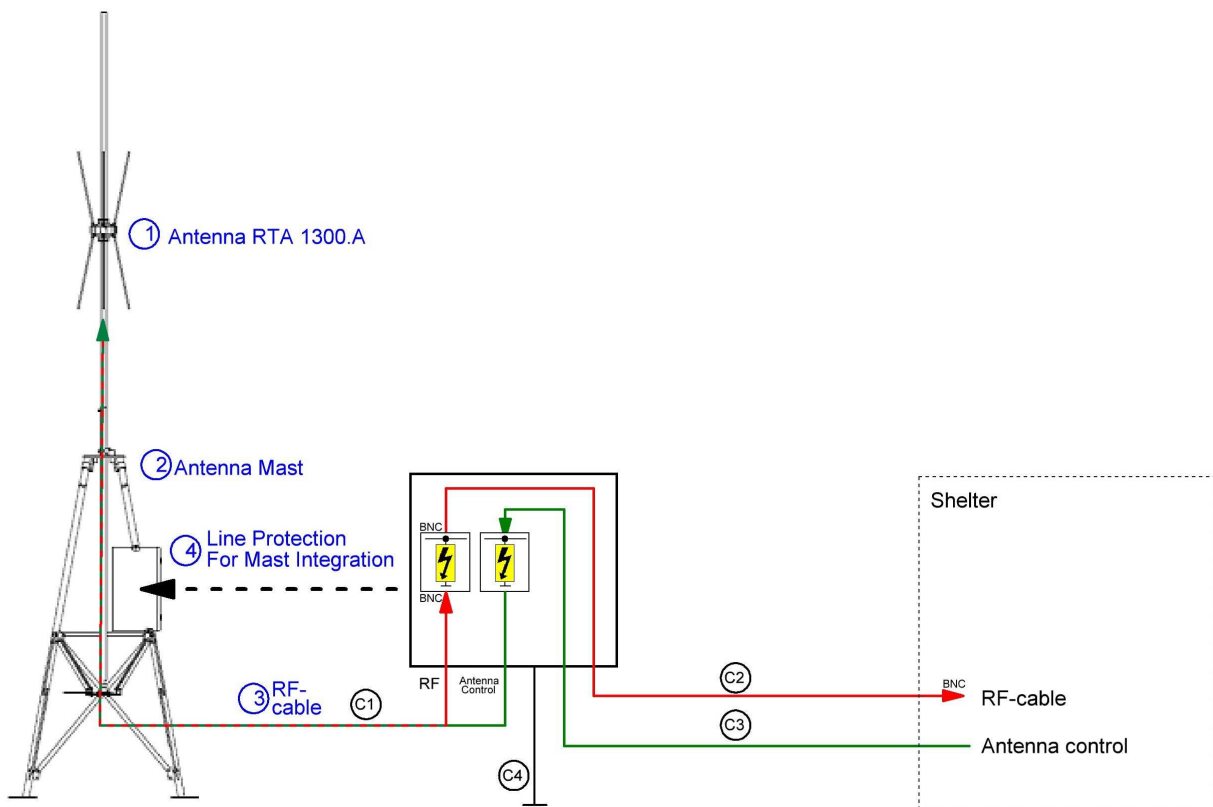

2.1 Component Description

System Components		
Nr.	Component	Description
1	Antenna RTA 1300.A	Antenna RTA 1300.A
2	Antenna Mast	Antenna Mast RTA-1306 A
3	RF-cable	RF-cable between Antenna Unit - Line protection box
4	Line Protection For Mast Integration	The line protection for mast integration includes all necessary components for overvoltage protection of antenna control lines and RF-Signal.

2.2 Description of External Cables

Cables			
Nr.	Description	Cable type	Length
C1	RF-cable between Antenna Unit – Line Protection Box	RHOTHETA Assemblies RTA-1307 A	4,5 m
C2	RF-cable between Line Protection Box – DF Main Unit	RG-400/U (RG-223)	18 m (max)
C3	Signal cable between Line Protection Box – DF Main Unit	6 x AWG 24 C UL, shielded	18 m
C4	Grounding cable	16mm ² (green yellow)	-

3 Front View

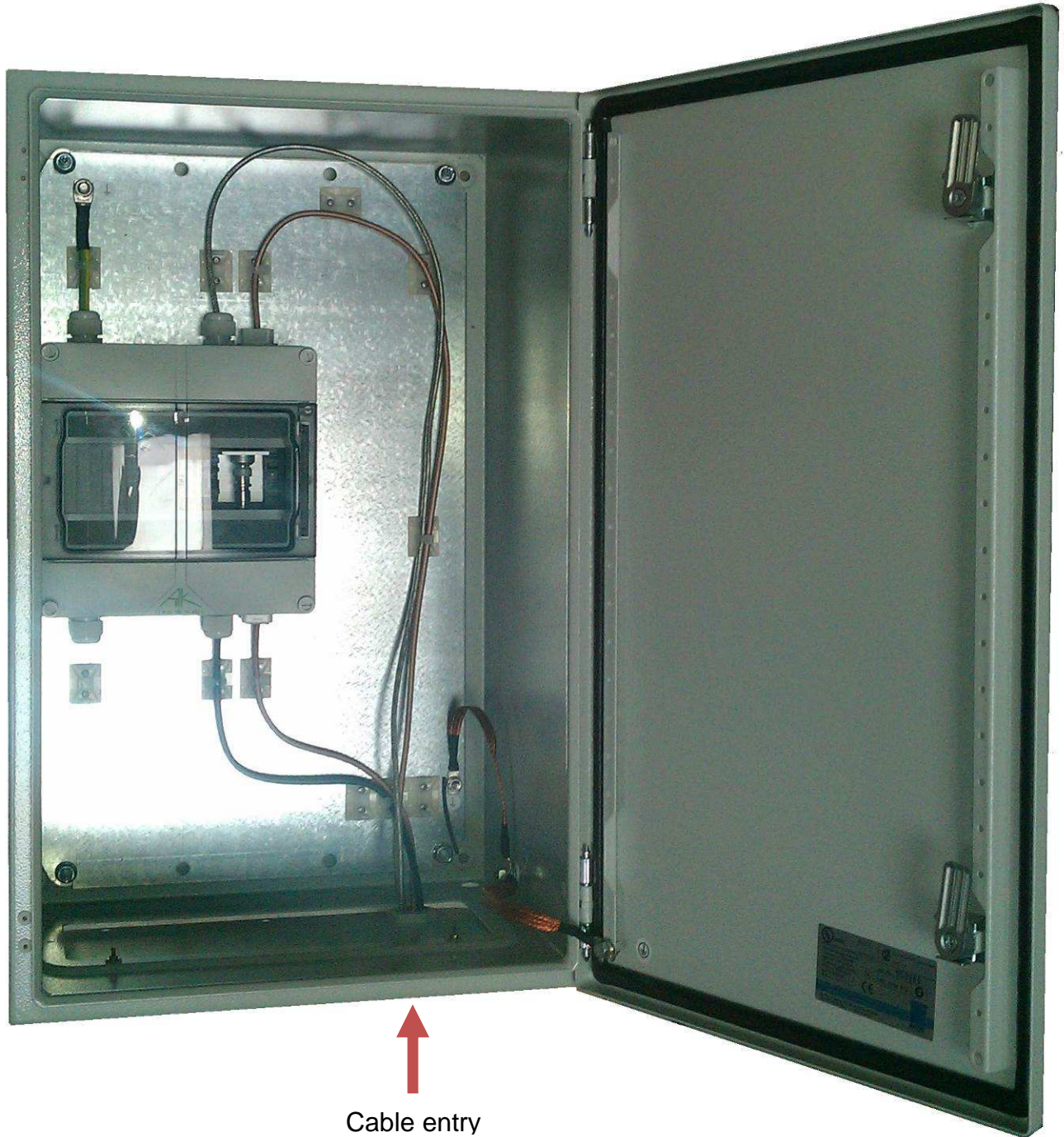

Cable entry

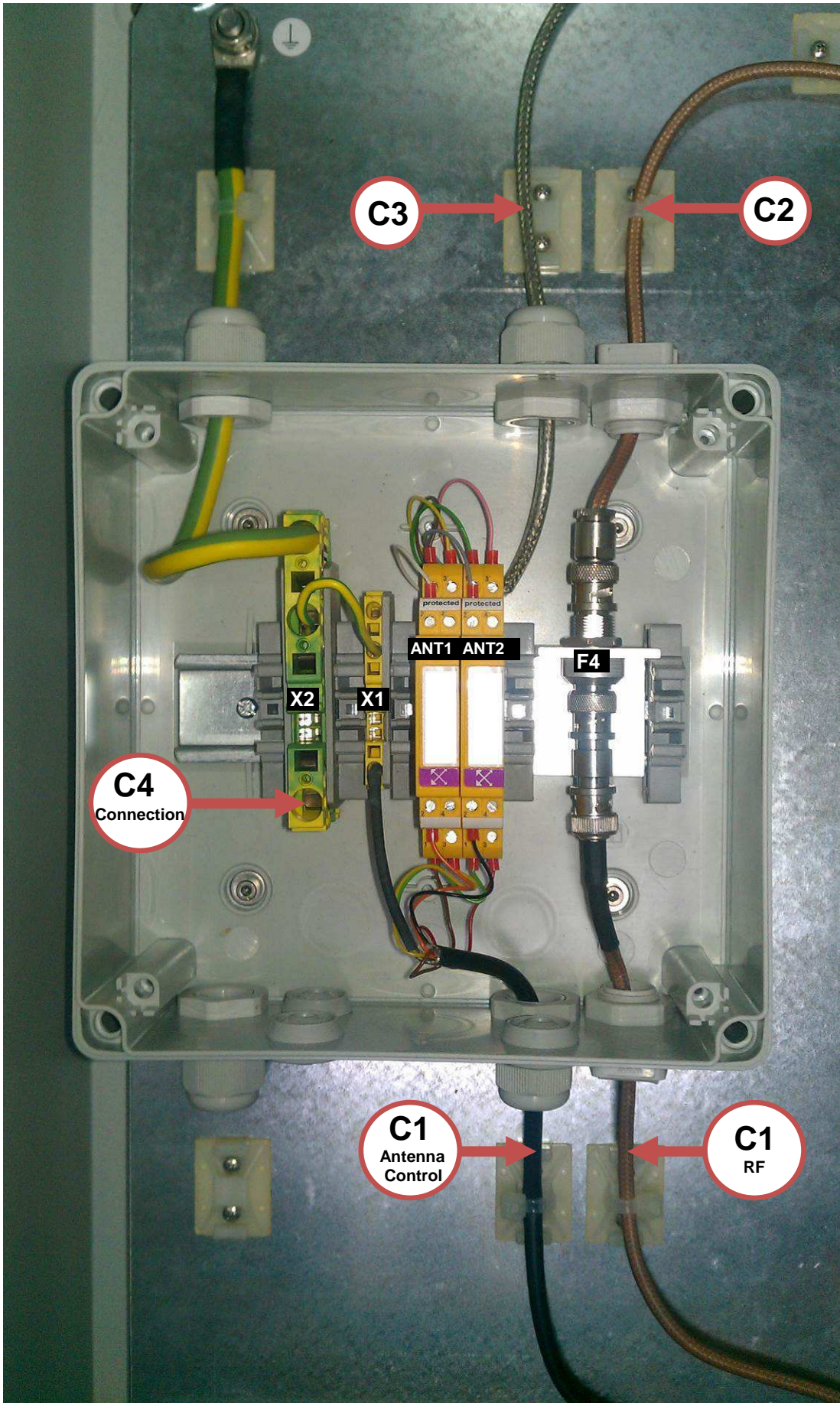

4 Mechanical Characteristics

Mechanical Characteristics						
Subsystem	Category IP	Material	Width	Height	Depth	Weight
Line Protection Box	IP 66	Stainless steel	380 mm	600 mm	350 mm	25 kg

5 Wiring Diagram

LINE PROTECTION FOR MAST INTEGRATION

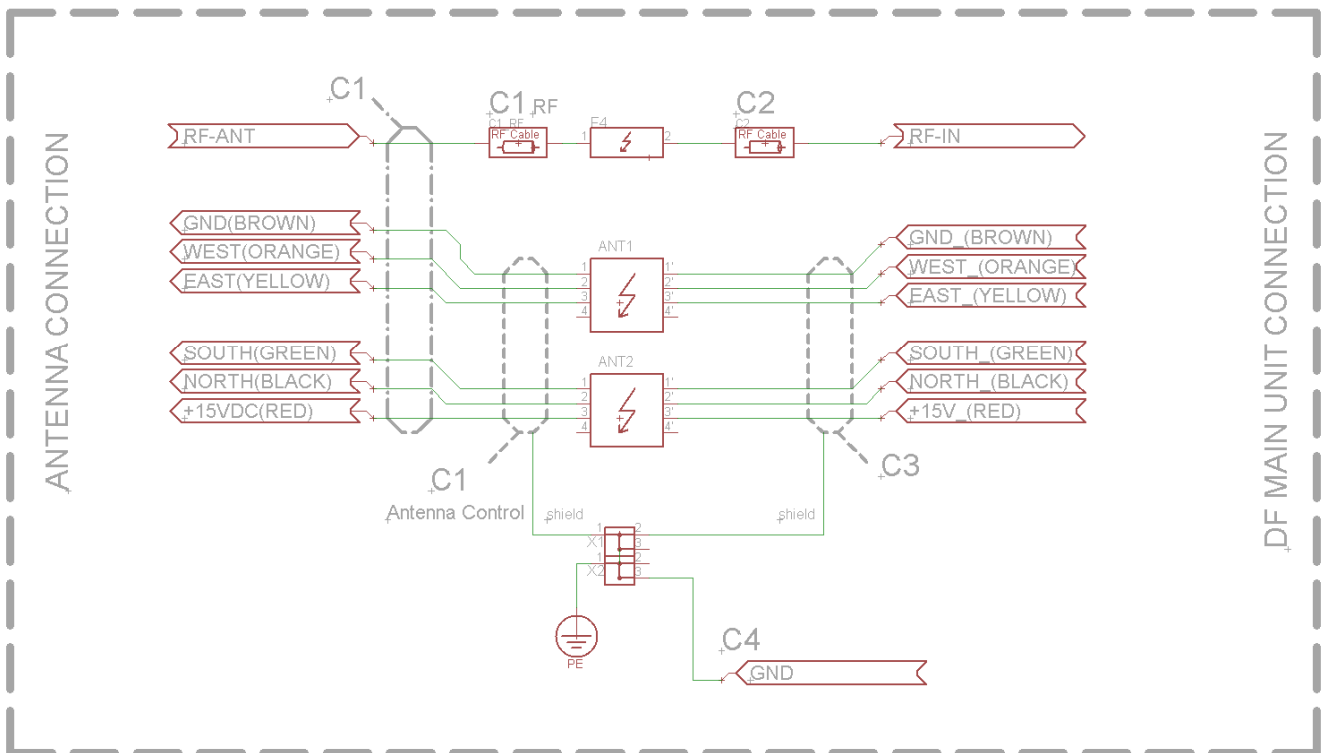

6 Notes