

RT-1000 MC All features at a glance

- Approved Doppler DF principle
- Extremely high rotation frequency for fast signal processing
- Compact antenna system for simple installation
- Effective lightning protection
- Very flexible system concept allows adaptation to almost every customer requirement
- Maintenance-friendly modular design
- Frequency range:
118.000 ... 136.975 MHz
156.000 ... 174.000 MHz

The Leader in DF



RHO
Elektronik GmbH

THETA

www.rhotheta.com

Mechanical characteristics

	Controller and Receiver Unit	Antenna
Weight:	Depends on configuration	Approx. 10.2 kg
Operating temperature:	-10°C to + 55°C	-40°C to + 80°C
Storage temperature:	-20°C to + 60°C	-40°C to + 80°C

DF Antenna Mast RTA-1300 A

with lightning protection rod and mast tube

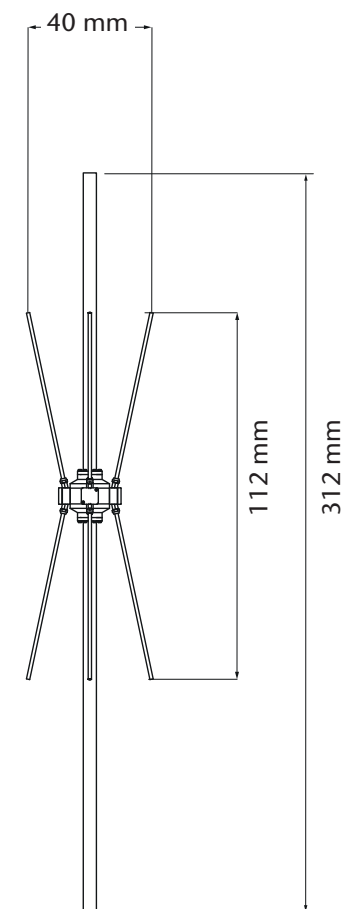

DF Antenna Mast RTA-1306

Antenna can be rotated

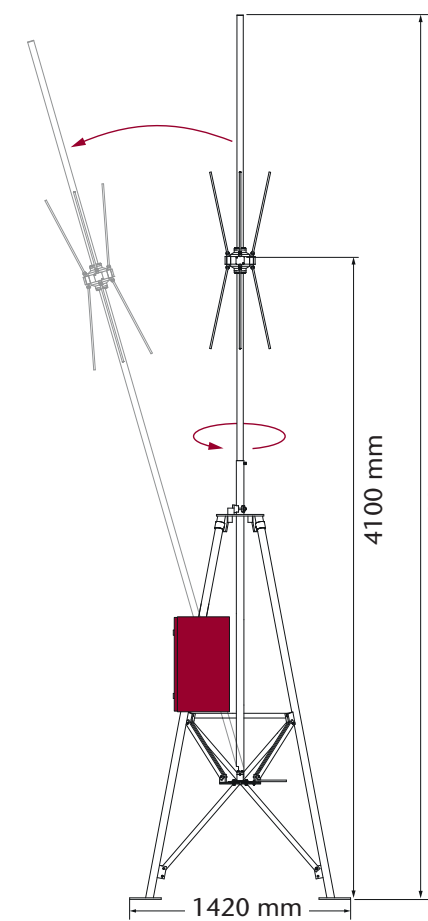

All product specifications subject to change without notice. All dimensions are in mm.



Coordinates: N 47.6842° / E 11.1982° / (WGS 84)

RHOTHETA Elektronik GmbH
Dr.-Ingeborg-Haekkel-Str. 2
82418 Murnau
Germany

Tel.: +49 8841 4879 - 0
Fax: +49 8841 4879 - 15
E-Mail: email@rhotheta.de

RHOTHETA International
8201 Peters Road Suite 1000
33324 Ft Lauderdale FL
USA

Tel.: +1 954 - 495-8700
Fax: +1 954 - 495-8477
E-Mail: info@rhothetaint.com
www.rhothetaint.com

www.rhotheta.com



Multichannel Radio Direction Finder RT-1000

The professional solution
for complex ATC and VTS
applications



The Leader in DF



RHO
Elektronik GmbH

THETA

www.rhotheta.com

The product



The RT-1000 Multichannel radio direction finder is designed for ATC (Air Traffic Control) and for VTS (Vessel Traffic Service). It is a very cost effective solution for applications where more than two simultaneous DF channels are required.

The modular design makes the system adaptable for almost all

modern DF applications up to 24 simultaneously DF-channels. The approved Doppler principle provides unrivaled system reliability. The compact antenna system is designed for very rough conditions and is easy to install.

The system flexibility allows almost every customer requirement to be fulfilled.

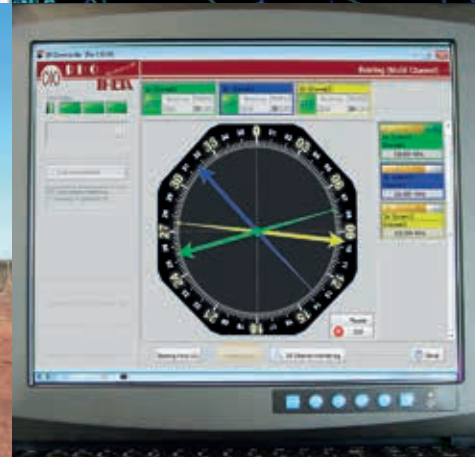
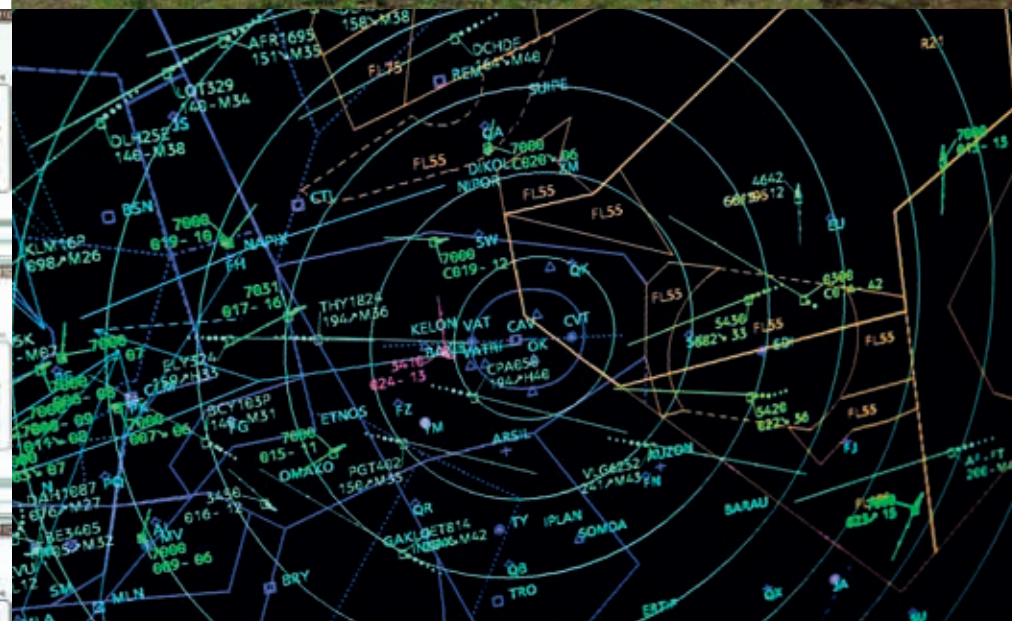

Technical data

Parameter	Condition	Data
DF method		Doppler (3 kHz rotation frequency)
Antenna type		Compact Doppler Antenna, 4 Dipole antennas
Number of DF channels	Simultaneous operation	Up to 24
Frequency range ¹	Air band VHF	118.000 – 136.975 MHz
	Marine band VHF	156.000 – 174.000 MHz ²
Channel spacing	Air band VHF	25 kHz
	Marine band VHF	25 kHz
	Air band VHF, option 8.33 kHz:	8.33 kHz and 25 kHz
Operating channels	Air band VHF	760 (25 kHz); 2278 (8.33 kHz)
	Marine band VHF	Channel 01 – 88 (incl. duplex channels)
Internal system resolution		0.5°
Bearing sensitivity	Air band VHF	±2° bearing fluctuation 3 μV/m typical
	VHF Marine band	±2° bearing fluctuation 3 μV/m typical ³
Bearing accuracy ⁴	118.000 – 136.975 MHz	±2° at 20 μV/m / 2° RMS
	156.000 – 174.000 MHz	2° RMS
	Option: Improved bearing accuracy	1° RMS
Polarization		vertical
Polarization error	Field vector rotation up to 45°	±1°
Cone of silence	Bearing error ≤ 5°	45°
Bearable modulation types		A3E, F3E, A2X (ELT Modulation)
Storage temperature range	Antenna unit RTA-1300 A	-40°C to + 80°C
	Bearing channel / Antenna control / RF Splitter	-40°C to + 60°C
Operating temperature range	Antenna unit RTA-1300 A	-40°C to + 80°C
	Bearing channel / Antenna control / RF Splitter	-40°C to + 60°C
Ingress protection	Antenna unit RTA-1300 A	IP65
Max. wind speed		270 km/h
Wind load	Antenna unit RTA-1300 A with constant wind speed	150 km/h: 135 N 180 km/h: 195 N

¹ Frequency range depends on the software configuration (Unlock options)

² This Frequency range is only valid without using the AIS Suppression

³ With dipole elements optimized for sea band operation

⁴ Measured in undisturbed wave field, with unmodulated signal, with sufficient signal strength

Installation and configuration example for single-site-solution

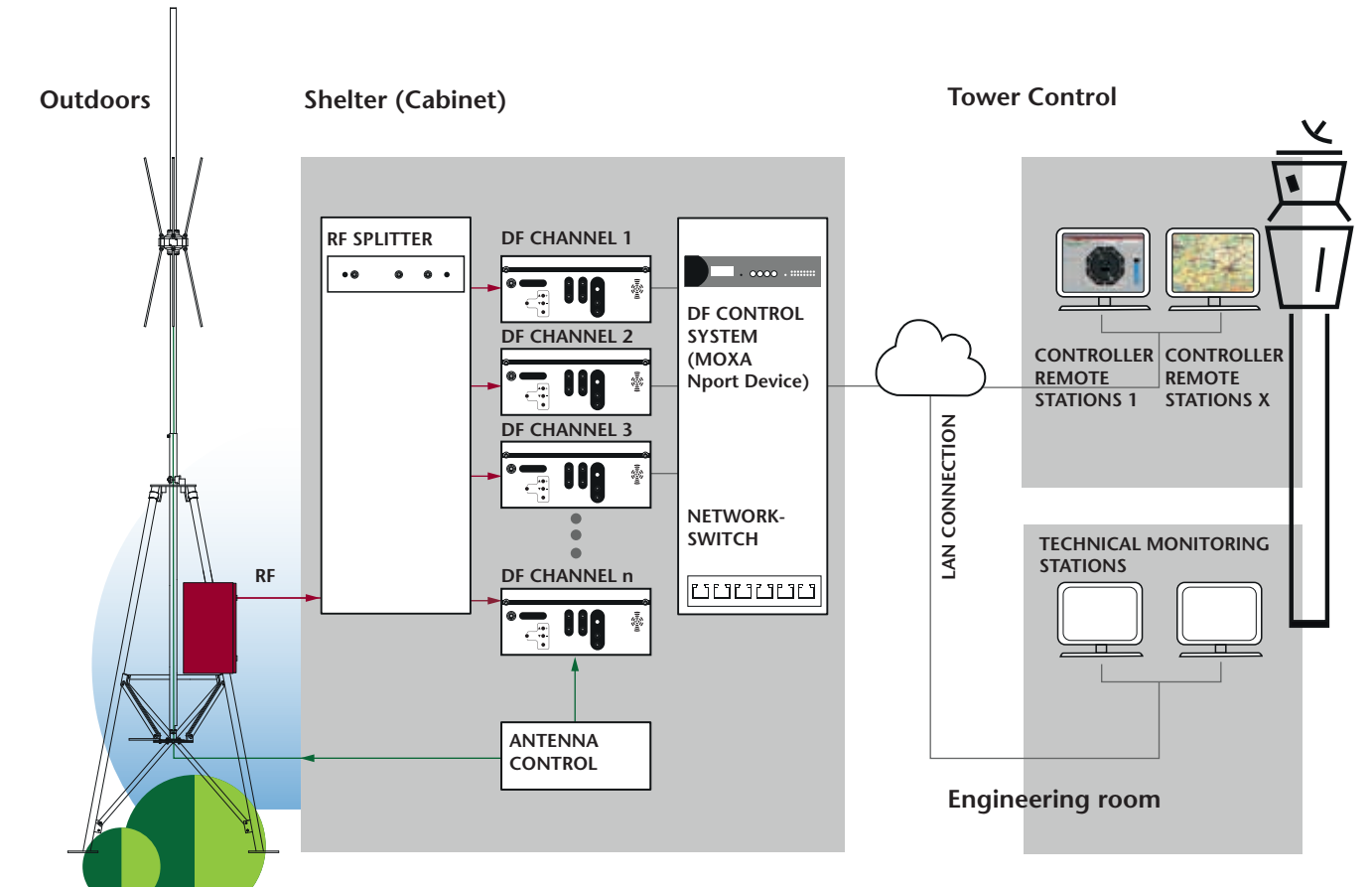

Installation and configuration example for multi-site-solution (triangulation)

